

TL0374J

0.03 – 3.0 GHz GaAs Ultra Low Noise Amplifier

Application Note: TL0374J EVB B

Application Note

2500MHz~2700MHz

5.0V 60mA

Rev-1.1

List of Contents

- 1 General Description
- 2 TL0374J-EVB-B Board Details
- 3 TL0374J -EVB-B Bill of Material
- 4 TL0374J -EVB-B Biasing sequence
- 5 TL0374J -EVB-B Board Measurement Summary
- 6 TL0374J -EVB-B Board Measurement Results

1. General Description

The TL0374J is a broadband, ultra-low Noise Amplifier (LNA) providing high gain and linearity. With a simple input and output match, this LNA can be tuned for different frequency bands targeting LTE (small cells and infrastructure) and any other applications requiring low noise, high gain, and linearity. For >3GHz frequency band, TL0375J can be considered. The TL0374J is packaged in a compact, low-cost Dual Flat No Lead (DFN) 2x2x0.75mm, 8 pin plastic package.

TL0374J-EVB-B is an evaluation board specially tuned for frequency range of 2500MHz~2700MHz applications. Its high gain, low noise performance makes it suitable.

2. TL0374J-EVB-B Board Details

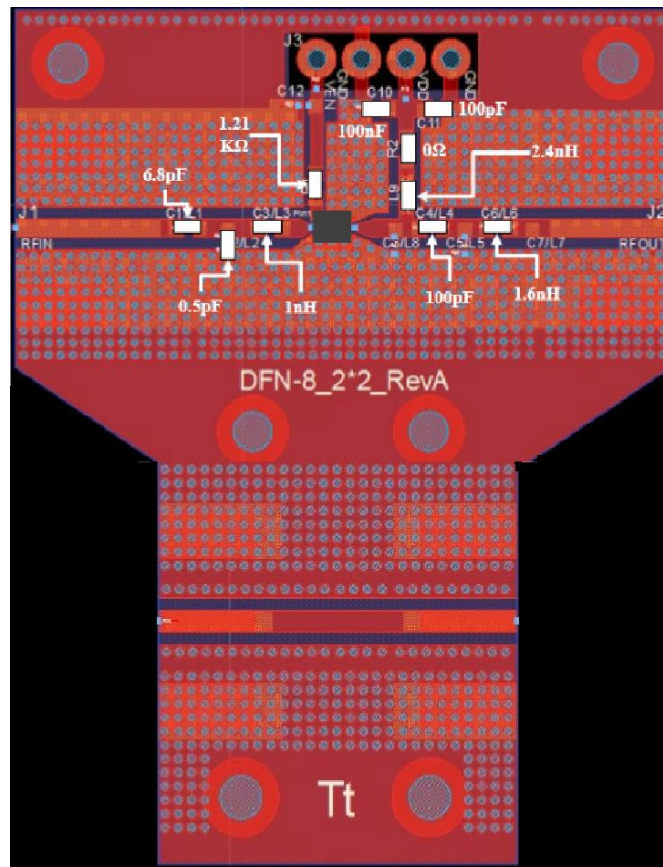
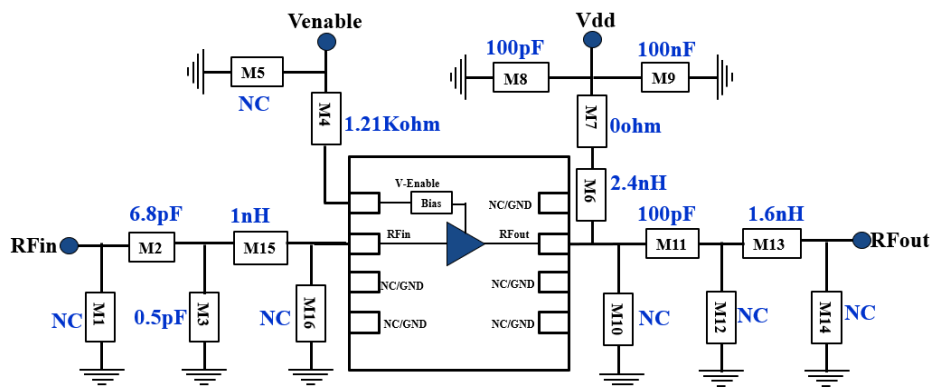

Figure 2.1 TL0374J-EVB-B 2500MHz ~ 2700MHz Schematic and EVB Layout

3. TL0374J-EVB-B Bill of Material

Component ID	Value	Manufacturer	Recommended Part Number
M2	6.8pF	Murata	GJM1555C1H6R8BB01
M3	0.5pF	Murata	GJM1555C1HR50BB01
M15	1nH	Coil craft	0402HP-1N0XJE
M4	1.21K Ω	Panasonic	ERJ-2RKF1211X
M8	100pF	AVX	04025A101JAT4A
M9	100nF	TDK	C1005X7R1H104K050BE
M7	0 Ω	Panasonic	ERJ-2GE0R00X
M6	2.4nH	Coil craft	0402HP-2N4XGE
M11	100pF	AVX	04025A101JAT4A
M13	1.6nH	Coil craft	0603HC-1N6XGLW
Q1	GaAs LNA	Tagore Technology	TL0374J
PCB		Rogers RO4350B, 20 mils, 1 oz copper	

Table 3.1 TL0374J-EVB-B BOM

4. TL0374J-EVB-B Biasing Sequence

Turn ON Device	Turn OFF Device
1. Set Venable to +5V 2. Set V_{DD} to +5V 3. Device will draw required I_{DQ} current 4. Apply RF power	1. Turn RF power off 2. Turn off V_{DD} 3. Turn off Venable

Table 4.1 TL0374J-EVB-B Bias and Sequencing

5. TL0374J-EVB-B Board Measurement Summary

Frequency (MHz)	EVB Noise figure (dB)	Gain(dB)	OP1 (dBm)	OIP3(dBm) Fspacing:1MHz 0dBm Pout/tone	S11(dB)	S22(dB)	Mu1
2500	0.5	19.2	19.0	41	-27	-9	1.2
2600	0.5	18.9	19.6	42	-33	-9.3	1.2
2700	0.5	18.5	18.4	43	-23	-9	1.2

Table 5.1 TL0374J-EVB-B Electrical Characteristics Summary

6. TL0374J-EVB-B Test Results

All the tests are carried out at room temperature.

6.1. S parameters

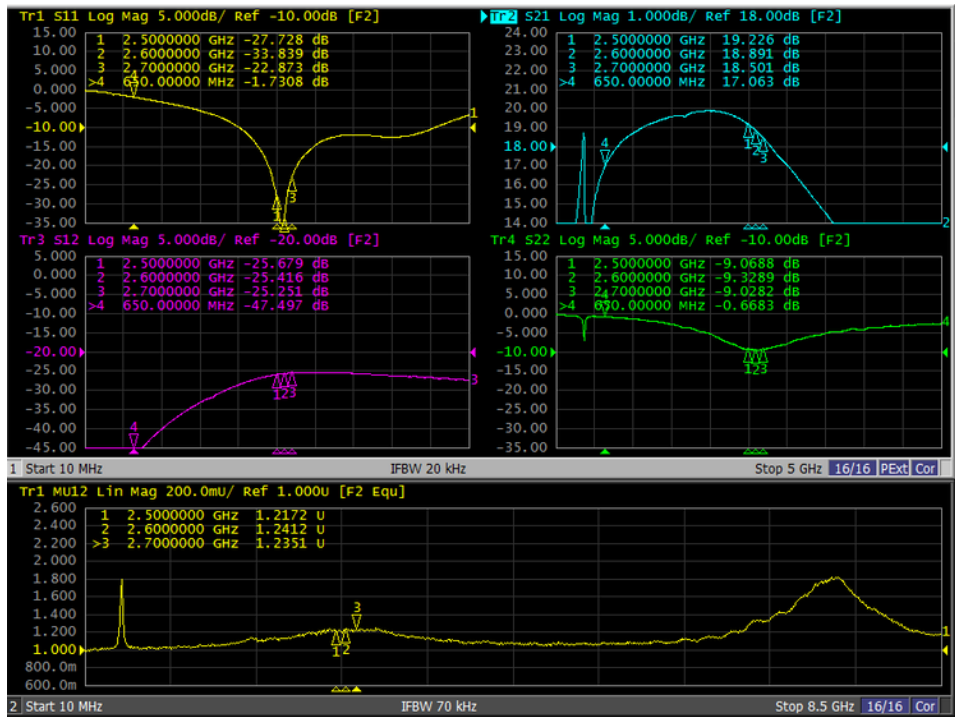

Figure 6.1.1. S parameters of TL0374J-EVB-B

6.2. SMA to SMA Noise Figure

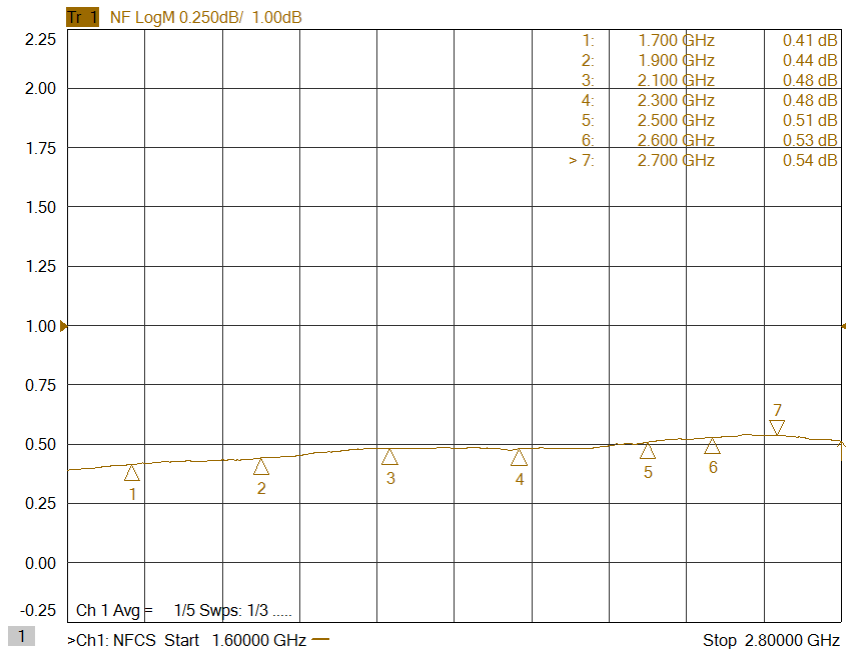

Figure 6.2.1 SMA to SMA NF of TL0374J-EVB-B

6.3. Large Signal Test Results

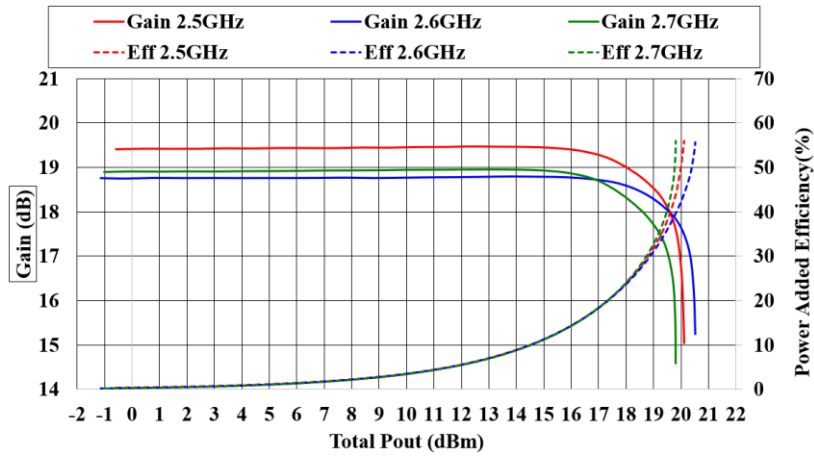

Figure 6.3.1. Gain Vs Pout of TL0374J-EVB-B

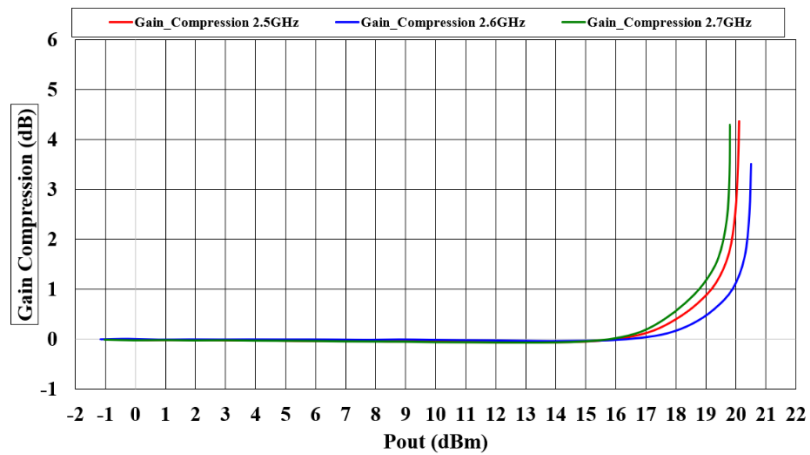

Figure 6.3.2. Gain compression Vs Pout of TL0374J-EVB-B

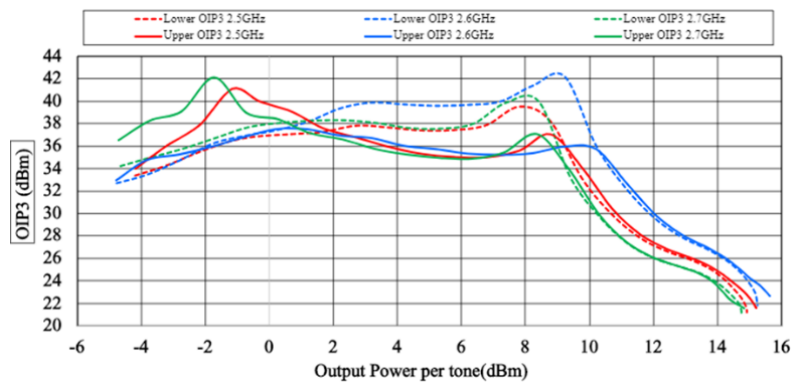

Figure 6.3.3. Output 3rd Order Intercept Point of TL0374J-EVB-B

Edition Revision 1.1 - 2023-11-08

Published by

Tagore Technology Inc.

601 W Campus Dr. Ste C1

Arlington Heights, IL 60004, USA

©2020 All Rights Reserved

Legal Disclaimer

The information provided in this document shall in no event be regarded as a guarantee of conditions or characteristics. Tagore Technology assumes no responsibility for the consequences of the use of this information, nor for any infringement of patents or of other rights of third parties which may result from the use of this information. No license is granted by implication or otherwise under any patent or patent rights of Tagore Technology. The specifications mentioned in this document are subject to change without notice.

Information

For further information on technology, delivery terms and conditions and prices, please contact Tagore Technology: support@tagoretech.com.