

TP0310K

27dBm CW 0.1-3.8GHz GaAs Power LNA

Application Note: TP0310K EVB A

Application Note

1700MHz~2000MHz

5.0V 140mA

Rev-1.1

List of Contents

- 1 General Description
- 2 TP0310K-EVB-A Board Details
- 3 TP0310K-EVB-A Bill of Material
- 4 TP0310K-EVB-A Biasing sequence
- 5 TP0310K-EVB-A Board Measurement Summary
- 6 TP0310K-EVB-A Board Measurement Results

1. General Description

The TP0310K is a power Low Noise Amplifier (LNA) providing high gain and linearity. With a simple input and output match, this LNA can be tuned for different frequency bands targeting low noise, high power, and high linearity over 0.1-3.8GHz frequency band. At 1.85 GHz, the amplifier typically provides 16.5 dB gain, 27.5dBm OP1, +39 dBm OIP3, and a 1.0 dB noise figure, while drawing 140-160 mA current from a +5 V supply.

TP0310K-EVB-A is an evaluation board specially tuned for frequency range of 1700MHz~2000MHz applications. Its application in the areas of Wireless infrastructure, smart cells, cellular repeaters, SDARs Mil/comm radios etc. The TP0310K is packaged in a compact, low-cost Dual Flat No Lead (QFN) 3x3x0.8mm, 16 pin plastic package.

2. TP0310K-EVB-A Board Details

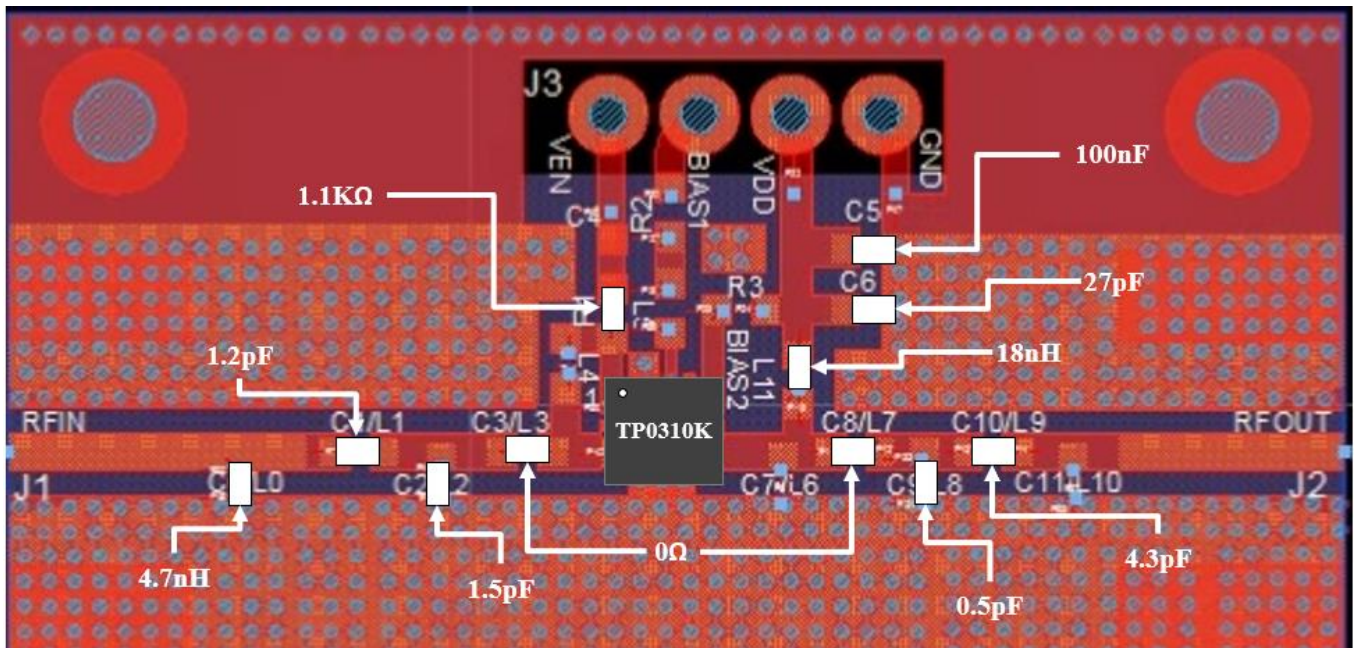
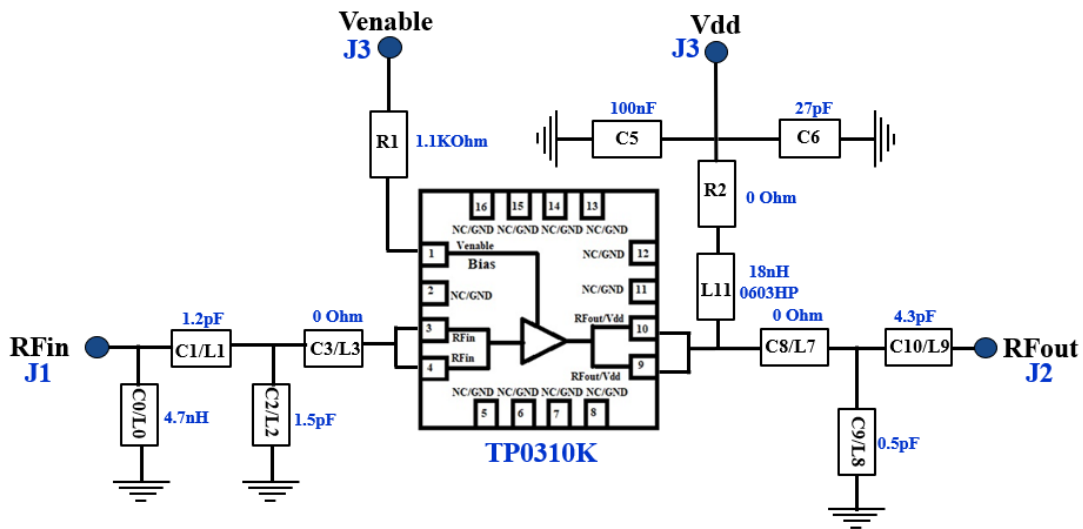

Figure 2.1 TP0310K-EVB-A 1700MHz ~ 2000MHz Schematic and EVB Layout

3. TP0310K-EVB-A Bill of Material

Component ID	Value	Manufacturer	Recommended Part Number
C0/L0	4.7nH	Coil craft	0402HP-4N7XGRW
C1/L1	1.2pF	Murata	GJM1555C1H1R2BB01
C2/L2	1.5pF	Murata	GJM1555C1H1R5BB01
R1	1.1K	Panasonic	ERJ-2RKF1101X
C9/L8	0.5pF	Murata	GJM1555C1HR50BB01
C10/L9	4.3pF	Murata	GJM1555C1H4R3BB01
C3/L3, C8/L7, R2	0 ohm	Panasonic	ERJ-2GE0R00X
L11	18nH	Coil craft	0402HP-18NXGRW
C5	100nF	TDK	C1005X7R1H104K050BE
C6	27pF	Murata	GJM1555C1H270JB01D
Q1	GaAs LNA	Tagore Technology	TP0310K
PCB		Rogers RO4350B, 20 mils, 1 oz copper	

Table 3.1 TP0310K-EVB-A BOM

4. TP0310K-EVB-A Biasing Sequence

Turn ON Device	Turn OFF Device
1. Set Venable to +5V 2. Set V _{DD} to +5V 3. Device will draw required I _{DQ} current 4. Apply RF power	1. Turn RF power off 2. Turn off V _{DD} 3. Turn off Venable

Table 4.1 TP0310K-EVB-A Bias and Sequencing

5. TP0310K-EVB-A Board Measurement Summary

Frequency (MHz)	EVB Noise figure (dB)	Gain(dB)	OP1 (dBm)	OIP3(dBm) 1MHz tone spacing & 8dBm power per tone	S11(dB)	S22(dB)	Mu1
1700	1	17.3	26.8	38.8	-13.3	-13.5	1.1
1850	1	16.8	27.5	39.0	-14.3	-11.4	1.1
2000	1.1	16.1	27.4	39.2	-11.2	-10.4	1.1

Table 5.1 TP0310K-EVB-A Electrical Characteristics Summary

6. TP0310K-EVB-A Test Results

All the tests are carried out at room temperature.

6.1. S parameters

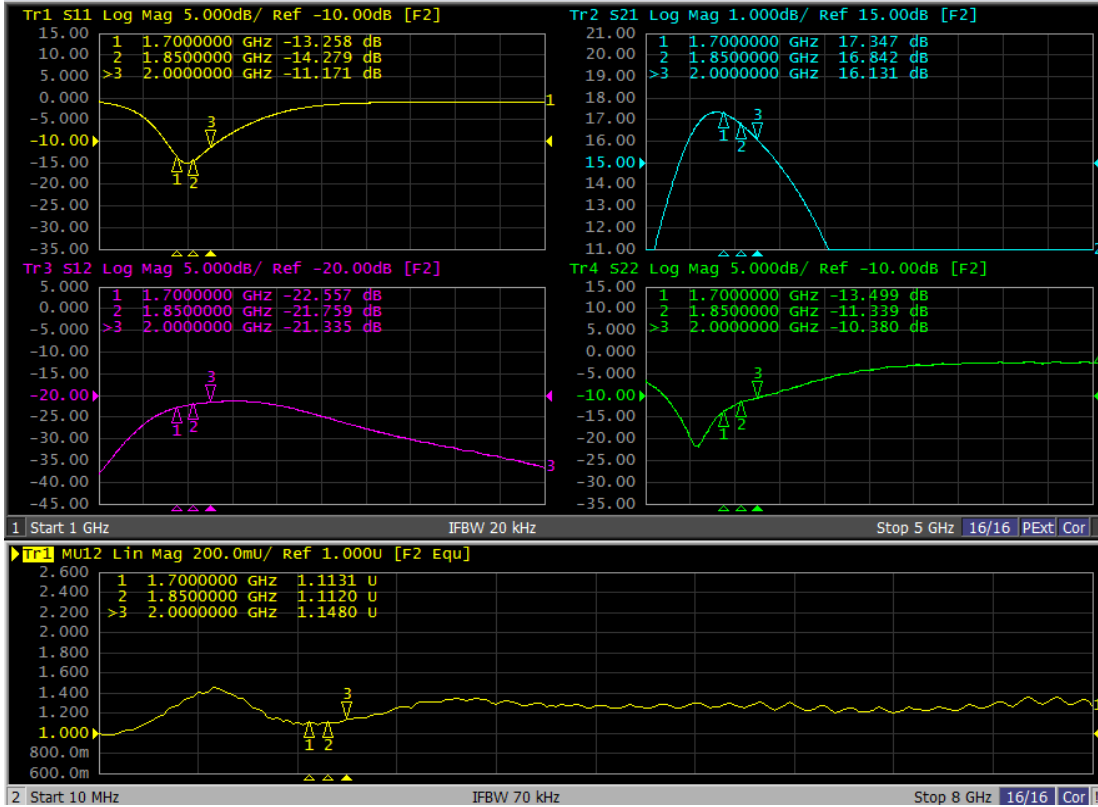

Figure 6.1.1. S parameters of TP0310K-EVB-A

6.2. SMA to SMA Noise Figure

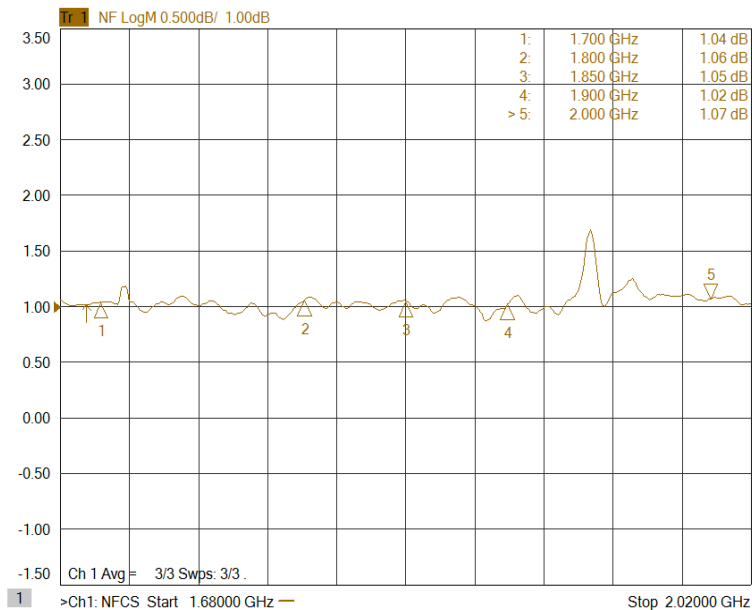

Figure 6.2.1 SMA to SMA NF of TP0310K-EVB-A

6.3. Large Signal Test Results

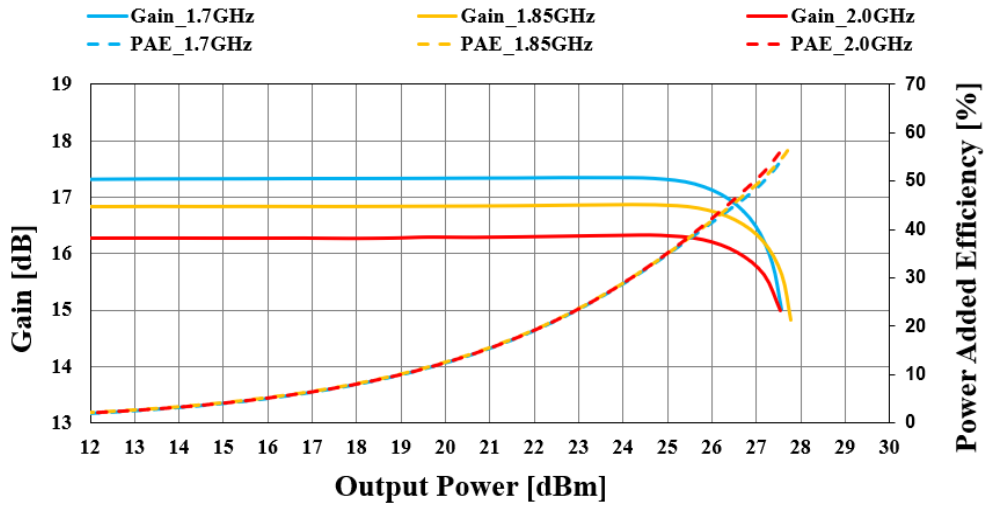

Figure 6.3.1. Gain Vs Pout of TP0310K-EVB-A

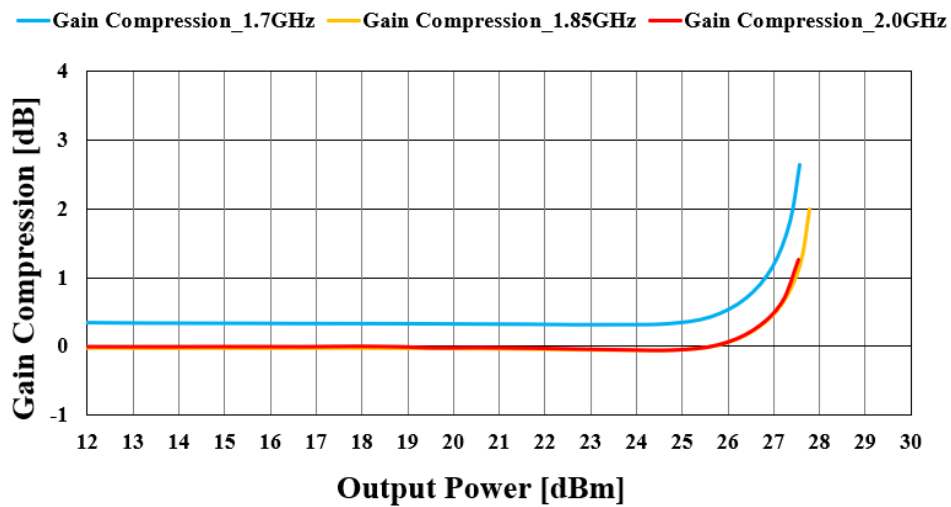

Figure 6.3.2. Gain compression Vs Pout of TP0310K-EVB-A

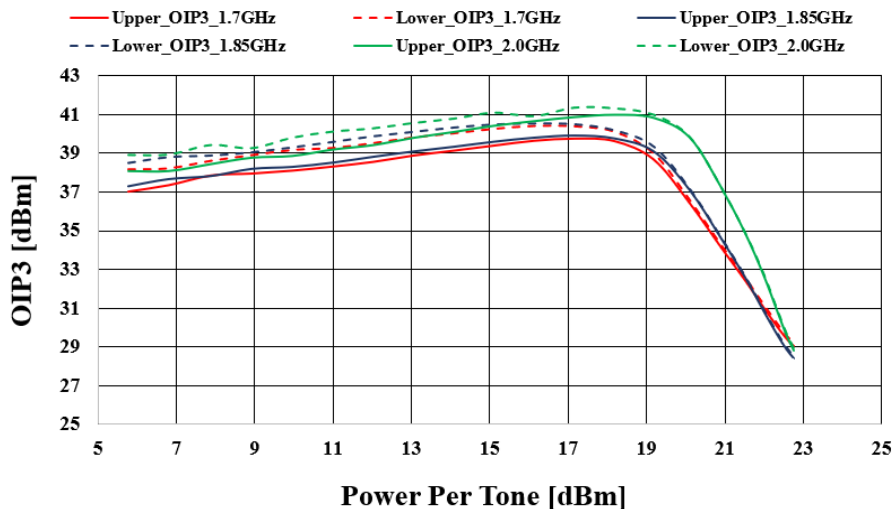

Figure 6.3.3. OIP3 Vs Pout per tone of TP0310K-EVB-A

6.4. ACPR Test Results

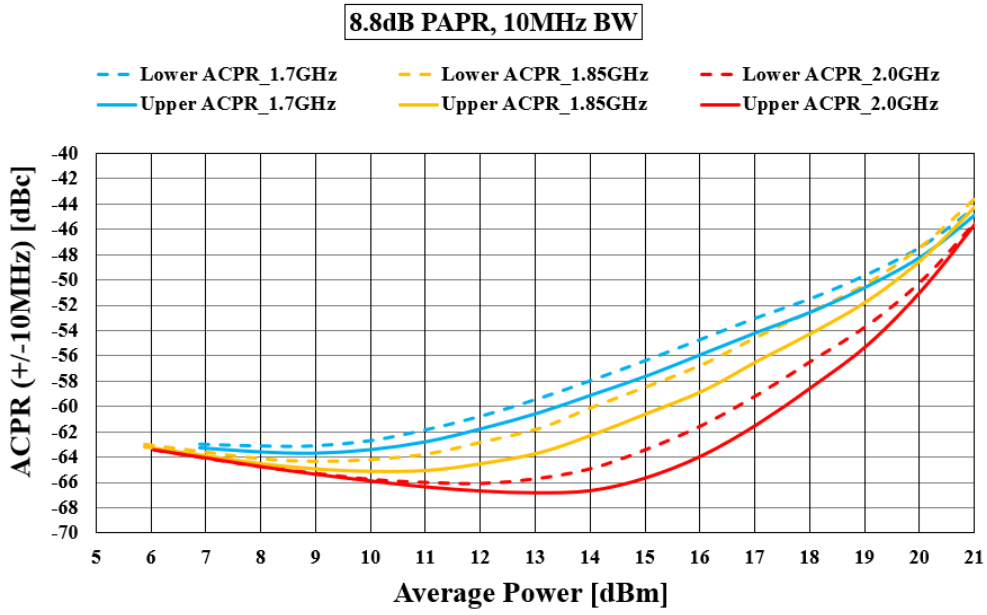

Figure 6.4.1. ACPR vs Average power of TP0310K-EVB-A

Edition Revision 1.1 - 2023-11-08

Published by

Tagore Technology Inc.

601 W Campus Dr. Ste C1

Arlington Heights, IL 60004, USA

©2020 All Rights Reserved

Legal Disclaimer

The information provided in this document shall in no event be regarded as a guarantee of conditions or characteristics. Tagore Technology assumes no responsibility for the consequences of the use of this information, nor for any infringement of patents or of other rights of third parties which may result from the use of this information. No license is granted by implication or otherwise under any patent or patent rights of Tagore Technology. The specifications mentioned in this document are subject to change without notice.

Information

For further information on technology, delivery terms and conditions and prices, please contact Tagore Technology: support@tagoretech.com.