

TA9310E

20 W CW 0.5 – 4.0 GHz GaN Power Transistor

Application Note: TA9310E EVB C

Application Note

1500 MHz~1800 MHz

30 V, 70 mA

Rev-2.1

List of Contents

- 1 General Description
- 2 TA9310E-EVB-C Board Details
- 3 TA9310E-EVB-C Bill of Material
- 4 TA9310E-EVB-C Biasing sequence
- 5 TA9310E-EVB-C Board Measurement Summary
- 6 TA9310E-EVB-C Board Measurement Results

1. General Description

The TA9310E is a broadband GaN power transistor capable of delivering 20 W CW from 500 MHz to 4.0 GHz frequency band. The transistor can be used at lower frequencies with reduced output power. The input and output can be matched for best power and efficiency for the desired band. The TA9310E is packaged in a compact, low-cost Dual Flat No lead (DFN) 5 x 6 x 0.75 mm, 8 leads plastic package.

TA9310E-EVB-C is tuned from 1500 MHz to 1800 MHz.

2. TA9310E-EVB-C Board Details

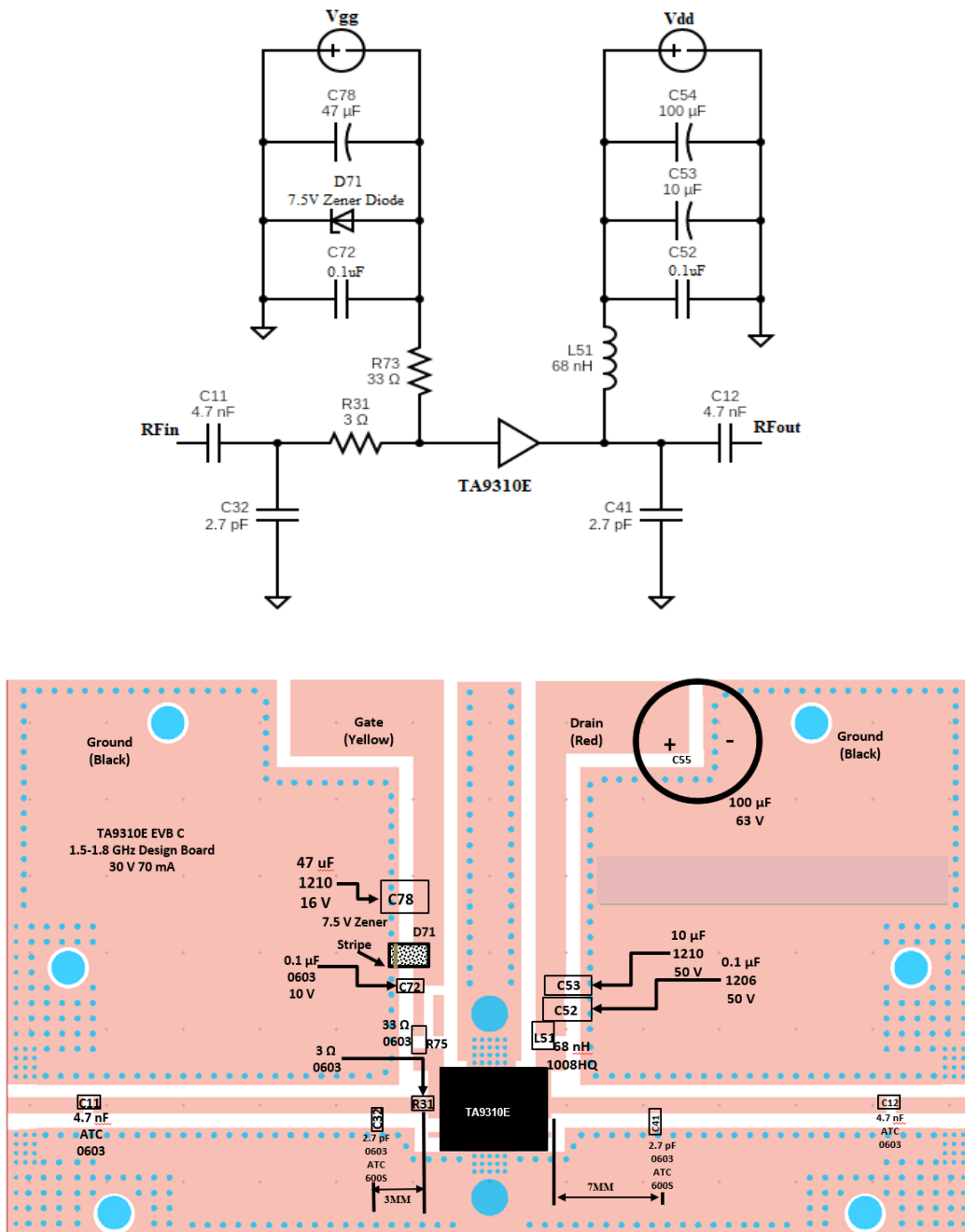

Figure 2.1 TA9310E-EVB-C 1500 MHz ~ 1800 MHz Schematic and EVB Layout

3. [TA9310E-EVB-C Bill of Material](#)

Component ID	Value	Manufacturer	Recommended Part Number
C11, C12	4.7 nF, 50 V	Murata	GRM1885C1H472JA01D
R31	3 Ω	Vishay	RCS06033R00FKEA
C32, C41	2.7 pF	ATC	600S2R7CT250XT
L51	68 nH	Coil craft	1008HQ-68NXGLC
C52	0.1 μ F, 50 V	Murata	GRM31C5C1H104JA01L
C53	10 μ F, 50V	Murata	GRM32ER71H106KA12L
C55	100 μ F, 63V	Nichicon	UPW1J101MPD1TD
D71	7.5 V Zener	On Semiconductor	SZMMSZ5236BT1G
C72	0.1 μ F, 10V	AVX	0603ZC104K4T2A
R75	33 Ω	Panasonic	ESR03EZPJ330
C78	47 μ F, 16 V	Murata	GRM32ER61C476ME15L
Q1	20 W GaN Transistor	Tagore Tech	TA9310E
PCB	Rogers RO4350B, 20 mils, 2 oz copper		

Table 3.1 TA9310E-EVB-C BOM

4. [TA9310E-EVB-C Biasing Sequence](#)

Turn ON Device	Turn OFF Device
1. Set V_G to -5 V 2. Set V_D to +30 V 3. Adjust V_G to reach required I_{DQ} current 4. Apply RF power	1. Turn RF power off 2. Turn off V_D 3. Turn off V_G

Table 4.1 TA9310E-EVB-C Bias and Sequencing

5. [TA9310E-EVB-C Board Measurement Summary](#)

Frequency (MHz)	S21 Gain(dB)	S11(dB)	S22(dB)	Psat(dBm)	PAE (%) @Psat
1500	15.5	-4.6	-7.1	43.2	44
1600	15.8	-5.6	-8.9	43.9	50
1700	16.0	-7.2	-12.8	43.8	59
1800	15.8	-8.8	-24.9	43.5	57

Table 5.1 TA9310E-EVB-C 30 V, 70 mA Electrical Characteristics Summary

6. TA9310E-EVB-C Test Results

All the tests are carried out at room temperature.

6.1. S parameters

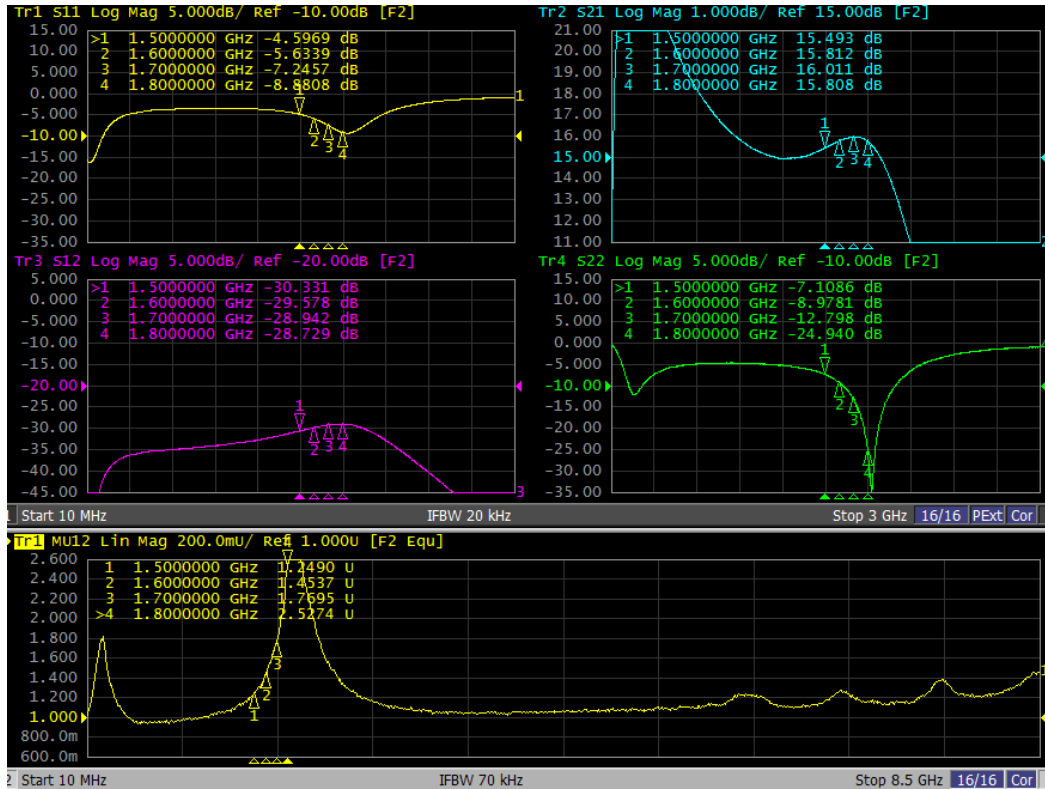

Figure 6.1.1. S parameters of TA9310E-EVB-C 30 V, 70 mA

6.2. Large Signal Test Results

Gain and PAE Vs P_{OUT} data and IRL and Pdiss Vs P_{OUT} [Vd=30 V, IdQ=70 mA, CW]

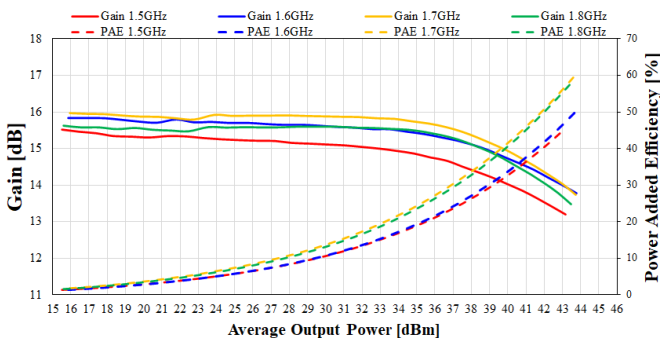

Figure 6.2.1. Gain and PAE vs P_{OUT} of TA9310E-EVB-C for 30 V, 70 mA for freq: 1500-1800 MHz

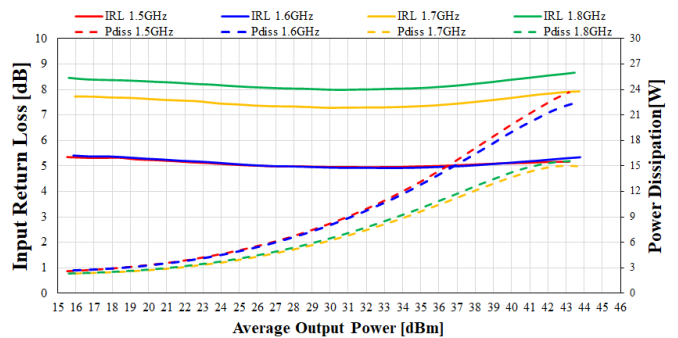

Figure 6.2.2. IRL and Pdiss vs P_{OUT} of TA9310E-EVB-C for 30 V, 70 mA for freq: 1500-1800 MHz

Edition Revision 2.1 - 2024-07-30

Published by

Tagore Tech Inc.

601 W Campus Dr. Ste C1

Arlington Heights, IL 60004, USA

©2024 All Rights Reserved

Legal Disclaimer

The information provided in this document shall in no event be regarded as a guarantee of conditions or characteristics. Tagore Tech assumes no responsibility for the consequences of the use of this information, nor for any infringement of patents or of other rights of third parties which may result from the use of this information. No license is granted by implication or otherwise under any patent or patent rights of Tagore Tech. The specifications mentioned in this document are subject to change without notice.

Information

For further information on technology, delivery terms and conditions and prices, please contact Tagore Tech: support@tagoretech.com.