

# TA9410E + 2xTS8441L

25 W CW 0.5 – 4.0 GHz GaN Power Transistor +  
30 W CW GaN Broadband RF Switch SP4T

**Application Note: TA9410E + TS8441L EVB G**

## Application Note

30~520 MHz

50 V, 50 mA

Rev-2.0

## List of Contents

- 1 General Description
- 2 TA9410E + TS8441L EVB-G Board Details
- 3 TA9410E + TS8441L EVB-G Bill of Material
- 4 TA9410E + TS8441L EVB-G Assembled Board Picture
- 5 TA9410E + TS8441L EVB-G RF Output & Frequency  
Band Selection
- 6 TA9410E + TS8441L EVB-G Biasing sequence
- 7 TA9410E + TS8441L EVB-G Board Measurement Summary
- 8 TA9410E + TS8441L EVB-G Board Measurement Results

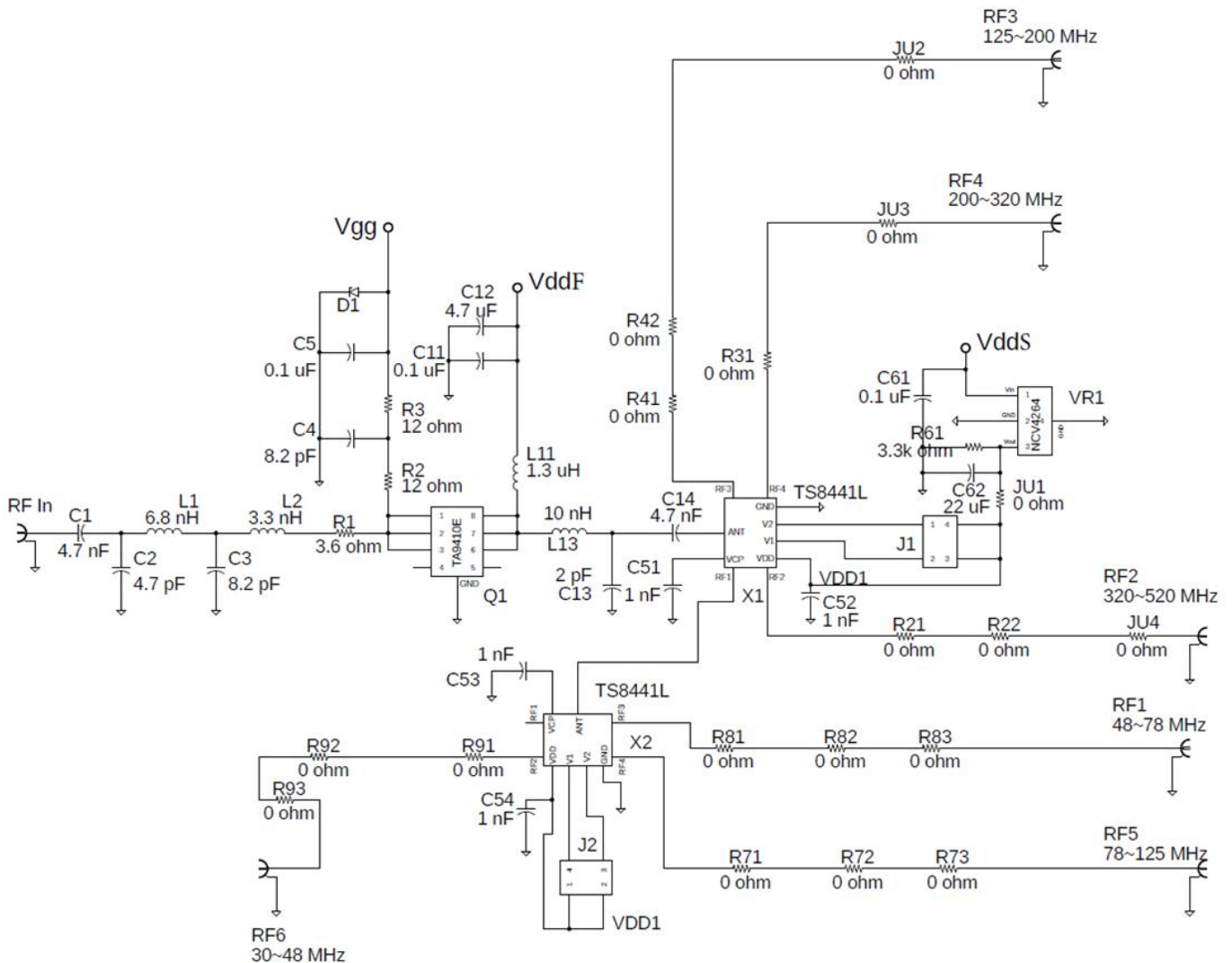
## 1. General Description

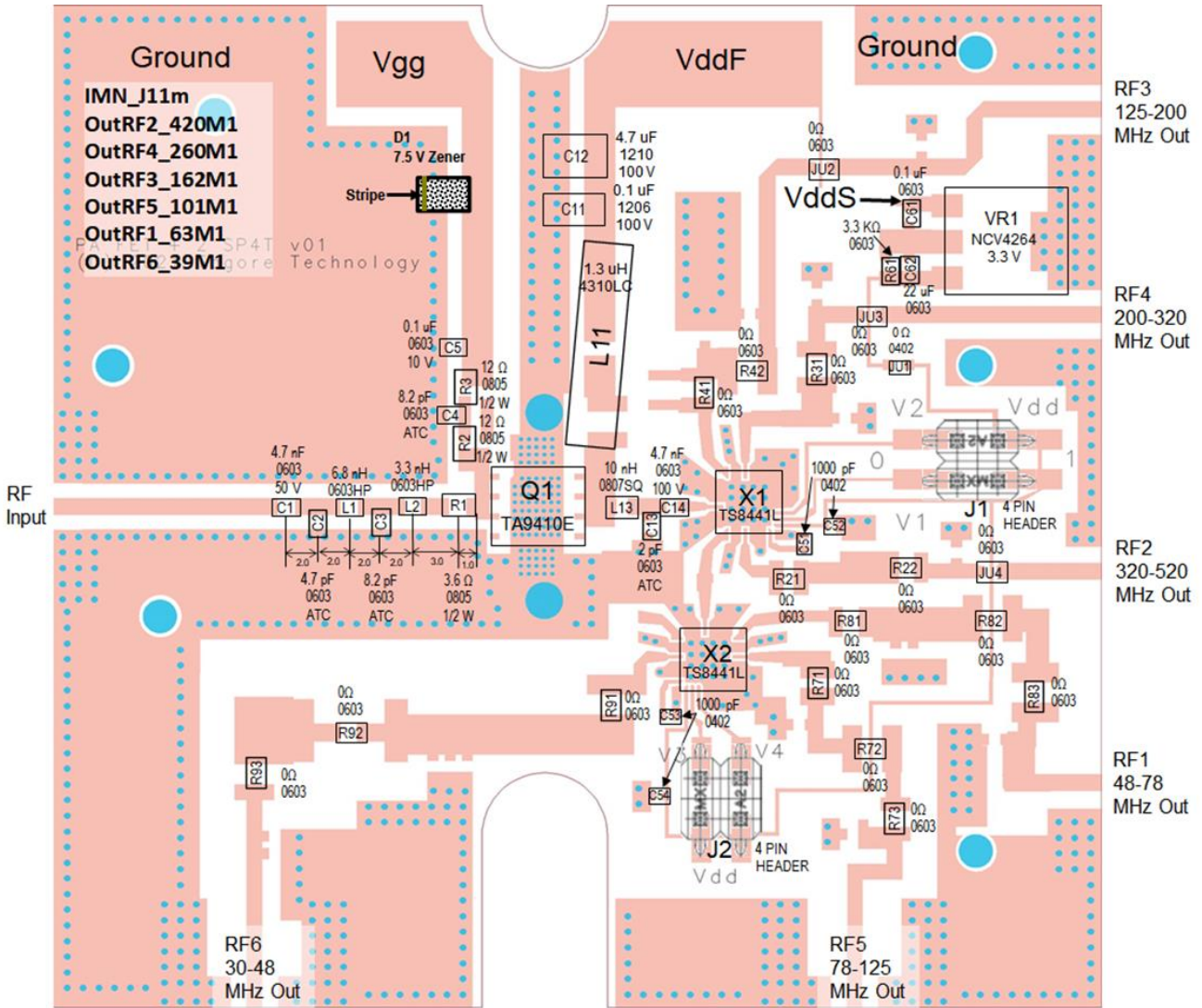
The TA9410E is a broadband GaN power transistor capable of delivering 25 W CW from 500 MHz to 4.0 GHz frequency band. The input and output can be matched for best power and efficiency for the desired band.

The TS8441L is a symmetrical reflective Single Pole Four Throws (SP4T) switch designed for broadband, high power switching applications. Its broadband behavior from 30 MHz to 4.0 GHz frequencies makes the TS8441L an excellent switch for all the applications requiring low insertion loss, high isolation, and high linearity within a small package size.

This combined design makes TA9410 to be fine-tuned for each communication frequency band. In another word, it expands the fine-tuned frequency range (30 ~ 520 MHz). The design can be applied in public safety or tactical radio system.

## 2. TA9410E+TS8441L EVB-G Board Details





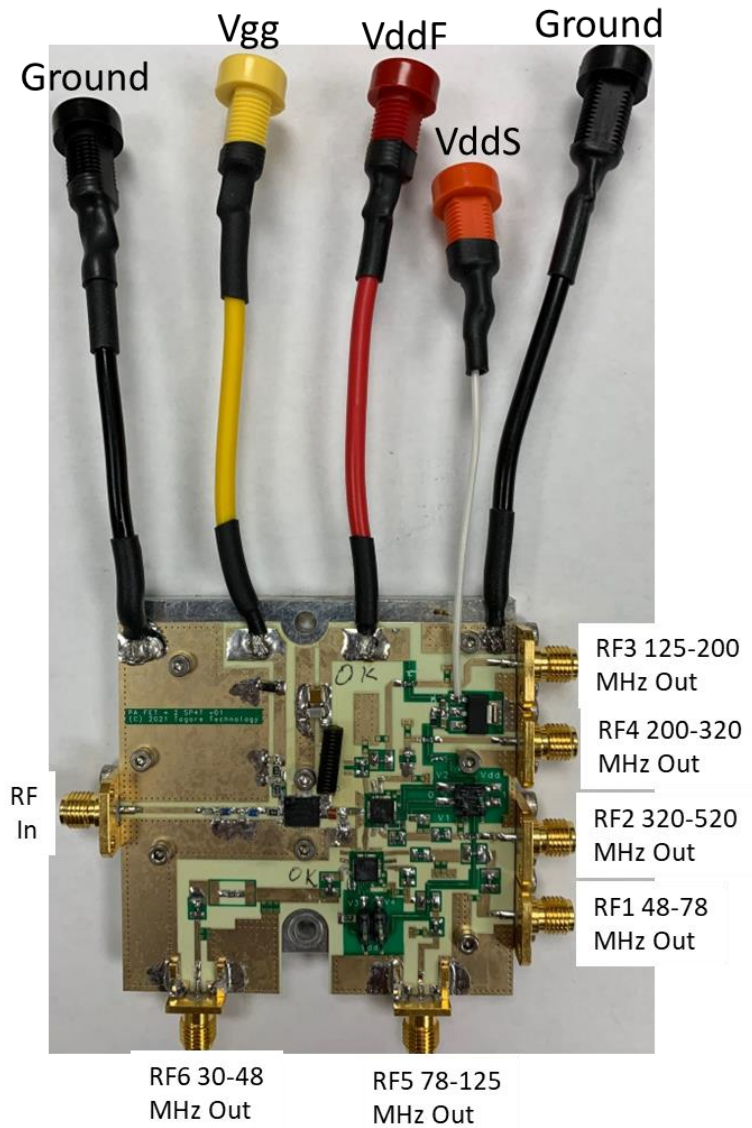
**Figure 2.1 TA9410E + TS8441L EVB-G 30 ~ 520 MHz Schematic and EVB Layout**

### 3. TA9410E+TS8441L EVB-G Bill of Material

Part Label	Part Description	Vendor Name	Vendor Part Number
C1	4.7 nF, 5%, 50 V, 0603	Murata	GRM1885C1H472JA01D
C2	4.7 pF, 5%, 250 V, 0603	ATC	600S4R7JT250XT
L1	6.8 nH, 5%, 0603	Coil craft	0603HP-6N8XJ
C3	8.2 pF, 5%, 250 V, 0603	ATC	600S8R2JT250XT
L2	3.3 nH, 5%, 0603	Coil craft	0603HP-3R3XJ
R1	3.6 $\Omega$ , 5%, 0805, 1/2 W	Panasonic	ERJ-P06J3R6V
R2, R3	12 $\Omega$ , 1%, 0805, 1/2 W	Panasonic	ERJ-P06F12R0V
C4	8.2 pF, 5%, 250 V, 0603	ATC	600S8R2JT250XT
C5	0.1 $\mu$ F, 20%, 10 V, 0603	AVX	0603ZC104K4T2A
D1	7.5V Zener	On Semiconductor	MMSZ5236BT1G
Q1	25 W GaN Transistor	Tagore Tech	TA9410E
X1, X2	SP4T Switch	Tagore Tech	TS8441L
C51, C52, C53, C54	1 nF, 20%, 50 V, 0402	Murata	GCM155R71H102KA37J
VR1	3.3 V Regulator	On-Semiconductor	NCV4264-2CST33T3G
R61	3.3 K $\Omega$ , 5%, 0603	Vishay	CRCW06033K30JNEB
C61	0.1 $\mu$ F, 10%, 100 V, 0603	Murata	GCM188R72A104KA64D
C62	22 $\mu$ F, 20%, 6.3 V, 0603	Murata	GRM188R60J226ME0D
JU1	0 $\Omega$ , 0402	Vishay	CRCW04020000Z0E
J1, J2	4 Pin Header	Molex	15-91-2040
L11	1.3 $\mu$ H, 10%, 4310	Coil craft	4310LC-132K
C11	0.1 $\mu$ F, 5%, 100 V, 1206	Murata	GRM31C5C2A104JA01L
C12	4.7 $\mu$ F, 10%, 100 V, 1210	Murata	GCM32DC72A475KE02L
L13	10 nH, 2%, 0807	Coil craft	0807SQ-10NG
C13	2.0 +/-0.1 pF, 250 V, 0603	ATC	600S2R0BT250XT
C14	4.7 nF, 10%, 100 V, 0603	Murata	GCD188R72A472KA01D
JU2, JU3, JU4	0 $\Omega$ , 0603	Vishay	CRCW06030000Z0E
R21, R22, R31, R41, R42, R71, R72, R73, R81, R82, R83, R91, R92, R93	0 $\Omega$ , 0603	Vishay	CRCW06030000Z0E

**Table 3.1 TA9410E + TS8441L EVB-G BOM**

#### 4. TA9410E + TS8441L EVB-G Assembled Board Picture



**Figure 4.1 TA9410E + TS8441L EVB-G Assembled Board Picture**



## 5. TA9410E + TS8441L EVB-G RF Output & Frequency Band Selection

RF output / frequency selection is done by either placing jumper plugs across certain pins of J1 and J2 or applying voltages to these pins. The board as supplied is set up to use jumpers, since it has an on-board 3.3 V regulator to provide the switch bias voltage (Vdd). An external switch matrix could also be used in place of the jumper plugs.

To use an external supply for switch bias and band selection, it is first necessary to remove JU1, shown in the yellow box on Figure 5.1. Switch bias must be in the range of 2.7 – 5.0 V and is applied to the outermost pin's of J1 and J2 (i.e. the pins closest to the board edge). Band selection is then made by selectively applying switch bias voltage to selected pins marked V1...V4 in Figure 5.1.

The jumper / voltage settings for each band are shown in Table 5.1.

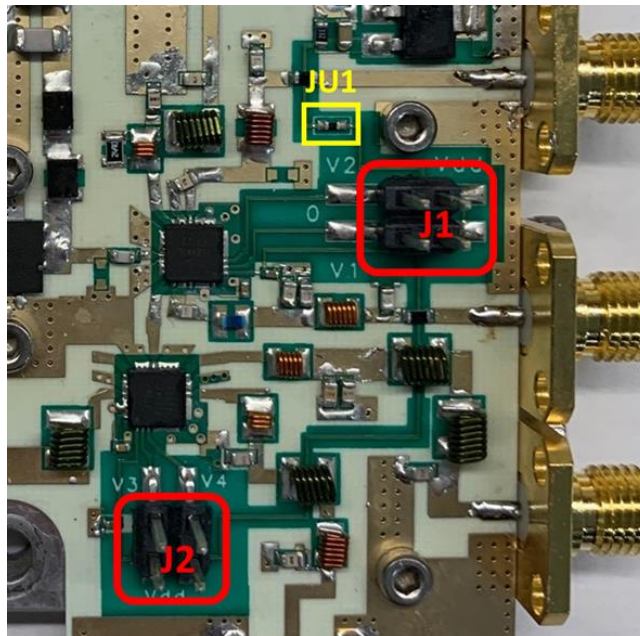


Figure 5.1 TA9410E + TS8441L EVB-G Assembled board Picture.

Frequency (MHz)	Port	Pin Voltages				Jumper Settings			
		V1	V2	V3	V4	V1	V2	V3	V4
320-520	RF2	3.3 V	0 V	0 V	0 V	Short	Open	Open	Open
200-320	RF4	3.3 V	3.3 V	0 V	0 V	Short	Short	Open	Open
125-200	RF3	0 V	3.3 V	0 V	0 V	Open	Short	Open	Open
78-125	RF5	0 V	0 V	3.3 V	3.3 V	Open	Open	Short	Short
48-78	RF1	0 V	0 V	0 V	3.3 V	Open	Open	Open	Short
30-48	RF6	0 V	0 V	3.3 V	0 V	Open	Open	Short	Open

**Table 5.1 Band Selection Table**

## 6. TA9410E + TS8441L EVB-G Biasing Sequence

Turn ON Device	Turn OFF Device
<ol style="list-style-type: none"> <li>1. Set jumpers or pin voltages to select the desired RF output.</li> <li>2. Connect selected output port to 50 <math>\Omega</math> load.</li> <li>3. Set VddS supply to a positive voltage between 6 V and 28 V, then connect to VddS terminal. This supply must be capable of sourcing at least 5 mA.</li> <li>4. Apply -5.5 V to Vgg terminal. This supply must be capable of sourcing or sinking at least 10 mA. Reversed gate current flow is possible at drive levels above 27 dBm.</li> <li>5. Connect power supply to VddF terminal. Set current limit at 1.3 A               <ol style="list-style-type: none"> <li>5.1. Start at 0.00 volts, then SLOWLY increase to + 50 V.</li> <li>5.2. Monitor VddF supply current (Id), stop increasing VddF if Id exceeds 20 mA.</li> </ol> </li> <li>6. SLOWLY raise Vgg (toward zero volts) until Id = 50 mA (Vgg should be between -2.5 V to -3.2V)</li> <li>7. Apply RF drive to RF input port.</li> </ol>	<ol style="list-style-type: none"> <li>1. Remove RF drive from RF input port.</li> <li>2. Decrease VddF to zero volts.</li> <li>3. Return Vgg to -5.5 V setting.</li> <li>4. Disconnect VddS supply.</li> </ol>

**Table 6.1 TA9410E + TS8441L EVB-G Bias and Sequencing**

## 7. TA9410E + TS8441L EVB-G Board Measurement Summary

Frequency (MHz)	Psat(dBm)	PAE%	Second Harmonic[dBc]	Third Harmonic[dBc]
30-48	44.0	72 @44.0 dBm Pout	-15 dBc @44.0 dBm	-14 dBc @44.0 dBm
48-78	44.2	72 @44.2 dBm Pout	-15 dBc @44.2 dBm	-14 dBc @44.2 dBm
78-125	44.0	69-70 @44.0 dBm Pout	-15 dBc @44.0 dBm	-13 dBc @44.0 dBm
125-200	44.5	68-70 @44.5 dBm Pout	-17 dBc @44.5 dBm	-14 dBc @44.5 dBm
200-320	44.0-44.4	62-67 @44.0 dBm Pout	-15 dBc @44.0 dBm	-14 dBc @44.0 dBm
320-520	44.2	57-62 @44.2 dBm Pout	-15 to -24 dBc @44.0 dBm	-15 to -24 dBc @44.0 dBm

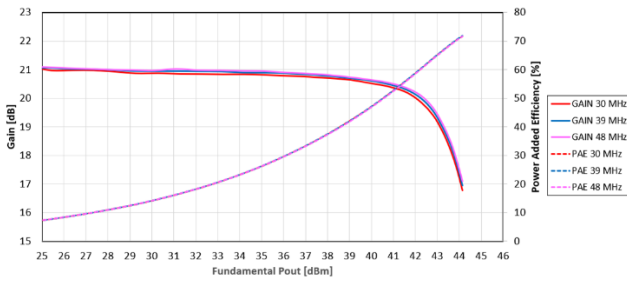
**Table 7.1 TA9410E + TS8441L EVB-G 50 V, 50 mA Electrical Characteristics Summary**



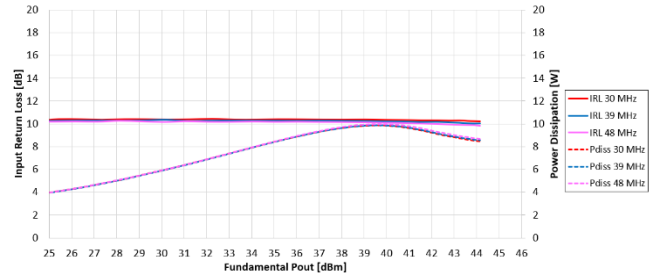
## 8. TA9410E + TS8441L EVB-G Test Results

### 8.1. Gain & PAE vs Pout, IRL & Pdis Vs Pout and H2-H3 dBc Vs Pout @50 V, 50 mA.

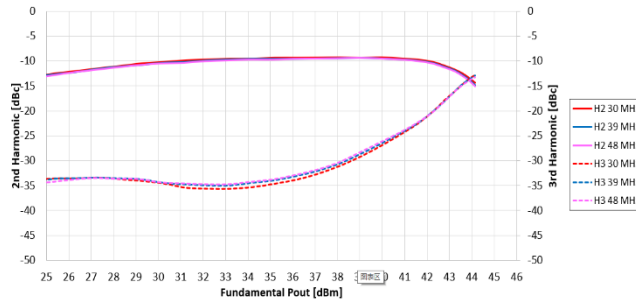
#### 30-48 MHz Band



**Figure 8.1.1 Gain, PAE v/s Pout Of TA9410E + TS8441L EVB-G, VD=50 V, IDQ=50 mA**

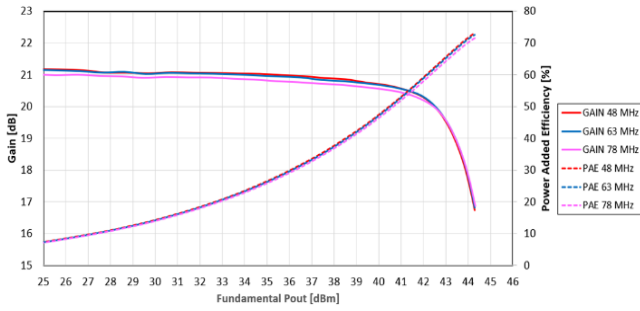


**Figure 8.1.2 IRL and Pdis v/s Pout Of TA9410E + TS8441L EVB-G, VD=50 V, IDQ=50 mA**

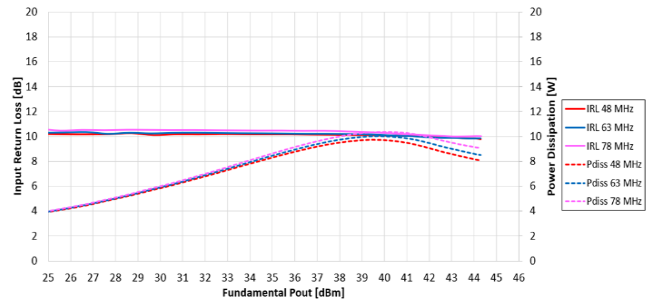


**Figure 8.1.3 H2dBc and H3dBc v/s Pout of TA9410E + TS8441L EVB-G, VD=50 V, IDQ=50 mA**

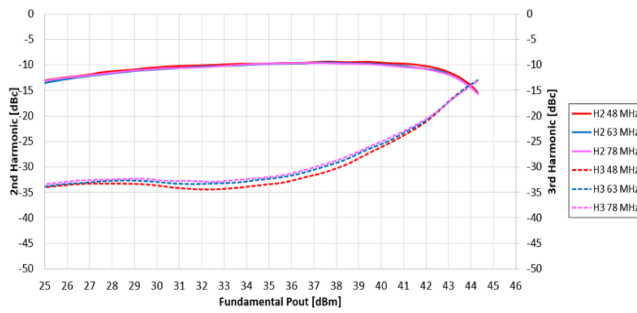
### 48-78 MHz Band



**Figure 8.1.4 Gain, PAE v/s Pout Of TA9410E + TS8441L EVB-G, VD= 50 V, IDQ= 50 mA**

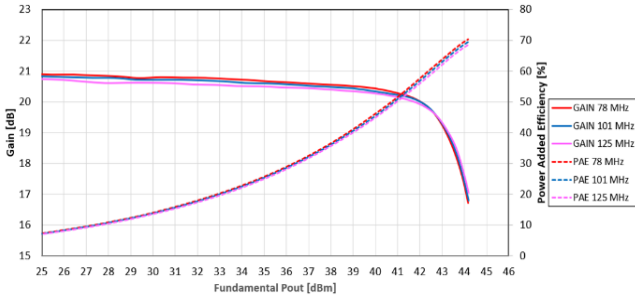


**Figure 8.1.5 IRL and Pdiss v/s Pout Of TA9410E + TS8441L EVB-G, VD= 50 V, IDQ= 50 mA**

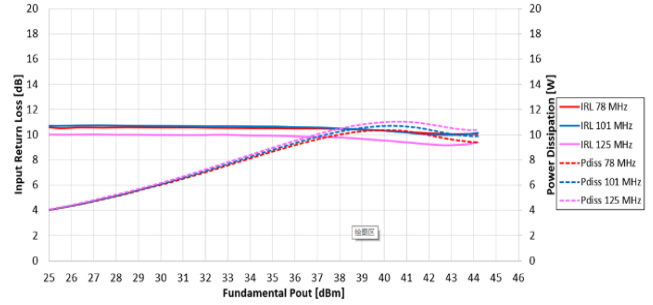


**Figure 8.1.6 H2dBC and H3dBC v/s Pout TA9410E + TS8441L EVB-G, VD= 50 V, IDQ= 50 mA**

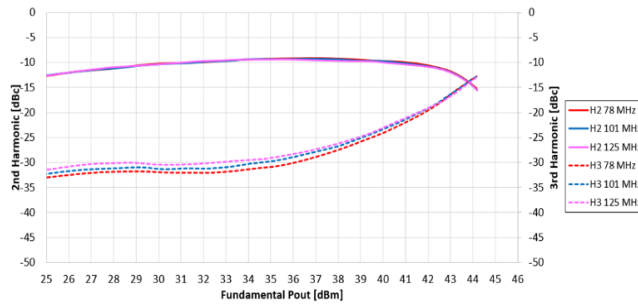
## 78-125 MHz Band



**Figure 8.1.7 Gain, PAE v/s Pout Of TA9410E + TS8441L EVB-G, VD= 50 V, IDQ=50 mA**

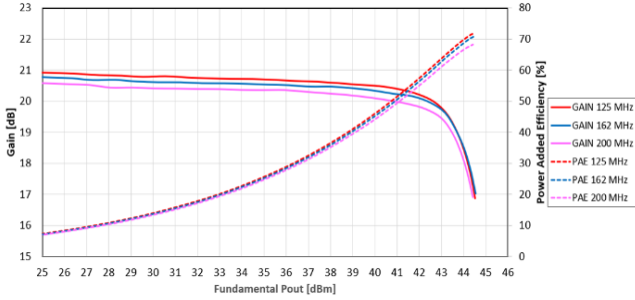


**Figure 8.1.8 IRL and Pdis v/s Pout Of TA9410E + TS8441L EVB-G, VD=50 V, IDQ=50 mA**

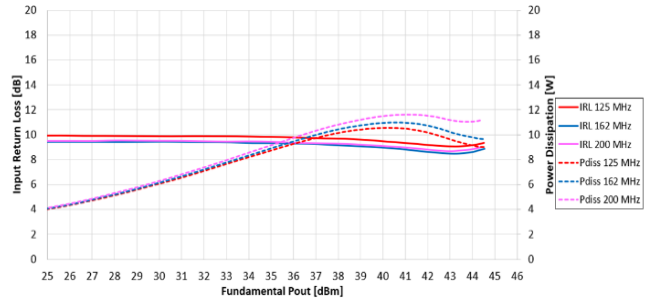


**Figure 8.1.9 H2dBc and H3dBc v/s Pout TA9410E + TS8441L EVB-G, VD=50 V, IDQ=50 mA**

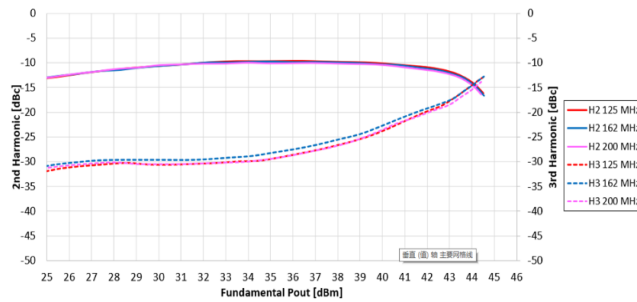
### 125-200 MHz Band



**Figure 8.1.10 Gain, PAE v/s Pout Of TA9410E + TS8441L EVB-G, VD=50 V, IDQ=50 mA**

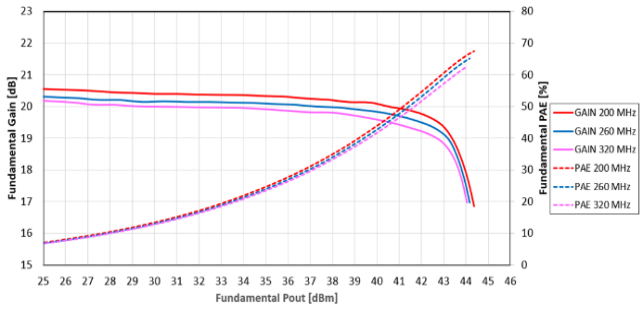


**Figure 8.1.11 IRL and Pdis v/s Pout. Of TA9410E + TS8441L EVB-G, VD=50 V, IDQ=50 mA**

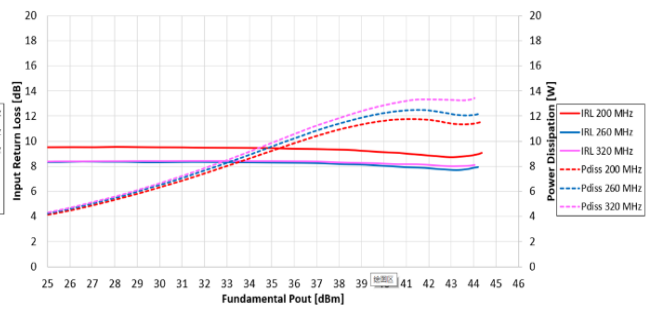


**Figure 8.1.12 H2dBC and H3dBC v/s Pout TA9410E + TS8441L EVB-G, VD=50 V, IDQ=50 mA**

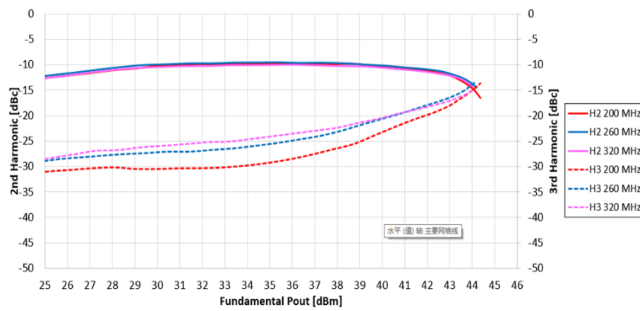
## 200-320 MHz Band



**Figure 8.1.13 Gain, PAE v/s Pout Of TA9410E + TS8441L EVB-G, VD=50 V, IDQ= 50 mA**

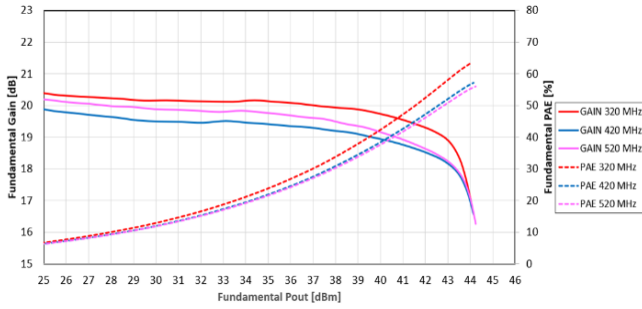


**Figure 8.1.14 IRL and Pdiss v/s Pout. Of TA9410E + TS8441L EVB-G, VD=50 V, IDQ=50 mA**

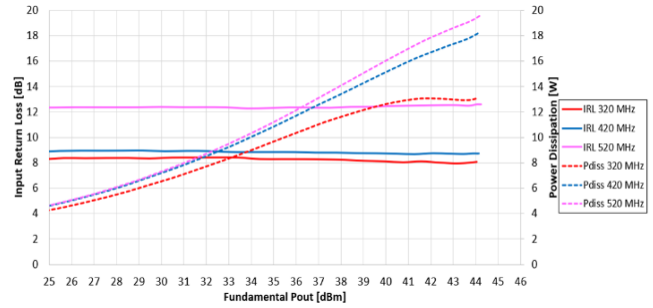


**Figure 8.1.15 H2dBC and H3dBC v/s Pout TA9410E + TS8441L EVB-G, VD=50 V, IDQ=50 mA**

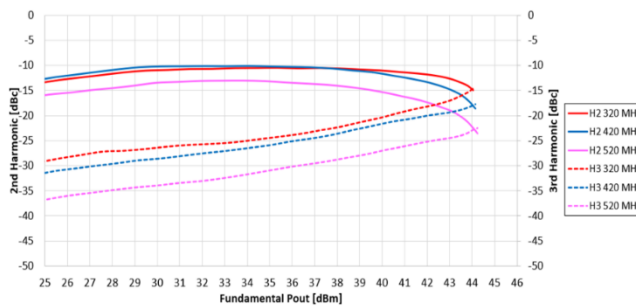
### 320-520 MHz Band



**Figure 8.1.16 Gain, PAE v/s Pout Of TA9410E + TS8441L EVB-G, VD=50 V, IDQ=50 mA**



**Figure 8.1.17 IRL and Pdiss v/s Pout. Of TA9410E + TS8441L EVB-G, VD=50 V, IDQ=50 mA**



**Figure 8.1.18 H2dBC and H3dBC v/s Pout TA9410E + TS8441L EVB-G, VD=50 V, IDQ=50 mA**



Edition Revision 2.0 - 2024-07-30

Published by

Tagore Tech Inc.

601 W Campus Dr. Ste C1

Arlington Heights, IL 60004, USA

©2024 All Rights Reserved

#### Legal Disclaimer

The information provided in this document shall in no event be regarded as a guarantee of conditions or characteristics. Tagore Tech assumes no responsibility for the consequences of the use of this information, nor for any infringement of patents or of other rights of third parties which may result from the use of this information. No license is granted by implication or otherwise under any patent or patent rights of Tagore Tech. The specifications mentioned in this document are subject to change without notice.

#### Information

For further information on technology, delivery terms and conditions and prices, please contact Tagore Tech: [support@tagoretech.com](mailto:support@tagoretech.com).