

# TL0374J

0.03 – 3.0 GHz GaAs Ultra Low Noise Amplifier

**Application Note: TL0374J EVB D1**

## Application Note

30 MHz~2600 MHz

3.3 V, 30 mA

Rev-2.3

## List of Contents

- 1 General Description
- 2 TL0374J-EVB-D1 Board Details
- 3 TL0374J -EVB-D1 Bill of Material
- 4 TL0374J -EVB-D1 Biasing sequence
- 5 TL0374J -EVB-D1 Board Measurement Summary
- 6 TL0374J -EVB-D1 Board Measurement Results

## 1. General Description

The TL0374J is a broadband, ultra-low Noise Amplifier (LNA) providing high gain and linearity. With a simple input and output match, this LNA can be tuned for different frequency bands targeting LTE (small cells and infrastructure) and any other applications requiring low noise, high gain, and linearity. For > 3 GHz frequency band, TL0375J can be considered. The TL0374J is packaged in a compact, low-cost Dual Flat No Lead (DFN) 2 x 2 x 0.75 mm, 8 pin plastic package.

TL0374J-EVB-D1 is an evaluation board specially tuned for 3.3 V, 30 mA for frequency range of 30 MHz~2600 MHz applications. Its high gain, low noise performance makes it suitable.

## 2. TL0374J-EVB-D1 Board Details

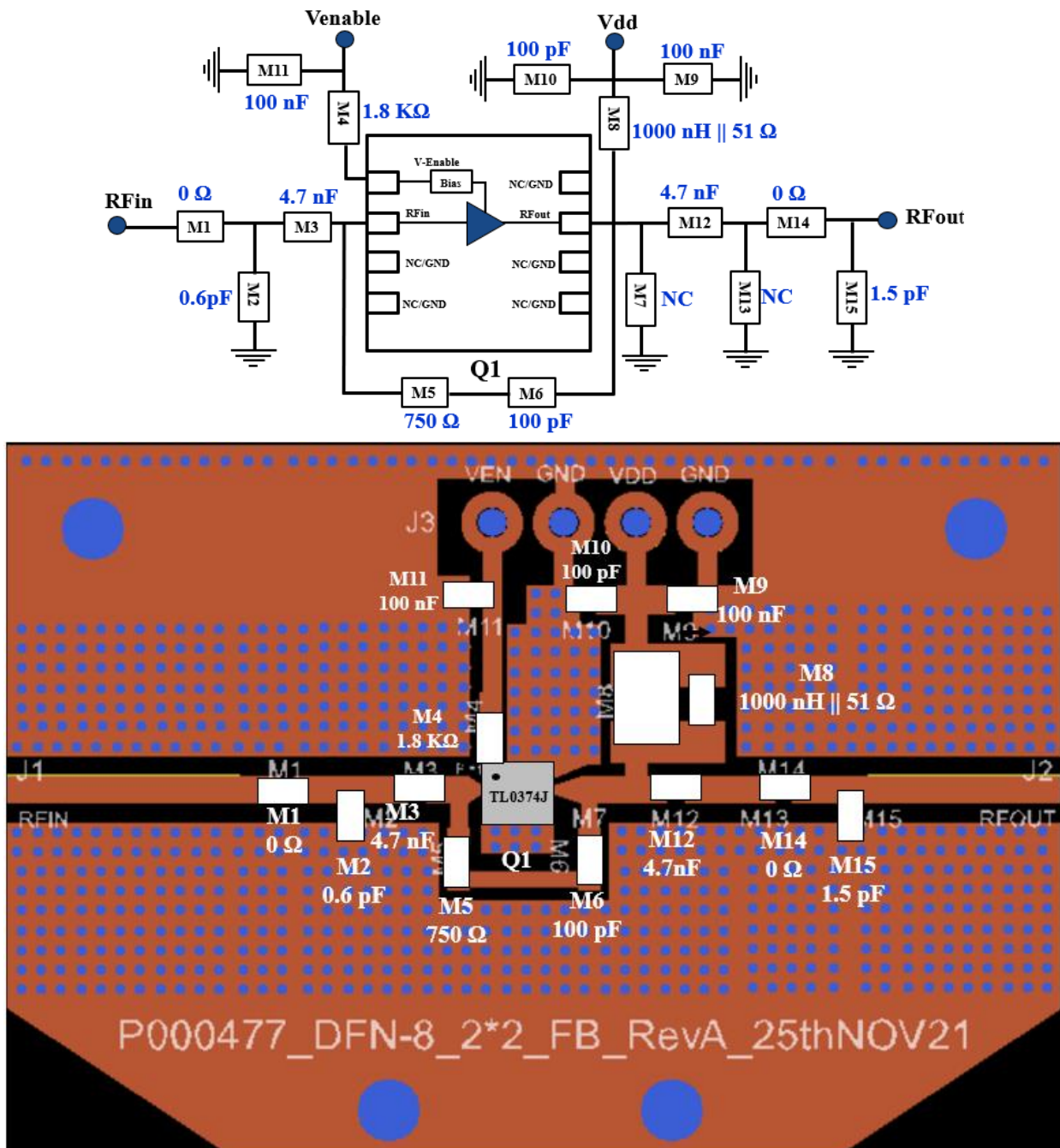

Figure 2.1 TL0374J-EVB-D1 30 MHz ~ 2600 MHz Schematic and EVB Layout

### 3. TL0374J-EVB-D1 Bill of Material

Component ID	Value	Manufacturer	Recommended Part Number
M1, M14	0 $\Omega$	Panasonic	ERJ-2GE0R00X
M2	0.6 pF	Murata	GJM1555C1HR60BB01D
M3, M12	4.7 nF, 50 V	Murata	GRM1885C1H472JA01D
M4	1.8 K $\Omega$	Panasonic	ERJ-2RKF1801X
M5	750 $\Omega$	KOA Speer	RK73H1ERTTP7500F
M6, M10	100 pF	AVX	04025A101JAT4A
M8	1 $\mu$ H	Coil craft	PFL2512-102MEC
M8	51 $\Omega$	ROHM Semiconductor	ESR03EZPJ510
M9, M11	100 nF	TDK	C1005X7R1H104K050BE
M15	1.5 pF	Murata	GJM1555C1H1R5BB01J
Q1	GaAs LNA	Tagore Tech	TL0374J
PCB		Rogers RO4350B, 20 mils, 1 oz copper	

**Table 3.1 TL0374J-EVB-D1 BOM**

### 4. TL0374J-EVB-D1 Biasing Sequence

Turn ON Device	Turn OFF Device
1. Set Venable to +3.3 V 2. Set V <sub>DD</sub> to +3.3 V 3. Device will draw required I <sub>DQ</sub> current 4. Apply RF power	1. Turn RF power off 2. Turn off V <sub>DD</sub> 3. Turn off Venable

**Table 4.1 TL0374J-EVB-D1 Bias and Sequencing**

### 5. TL0374J-EVB-D1 Board Measurement Summary

Frequency (MHz)	De-embedded Noise figure (dB)	Gain(dB)	OP1 (dBm)	OIP3(dBm) Fspacing:1 MHz 0 dBm Pout/tone	S11(dB)	S22(dB)	Mu1
30	1.0	20.3	12.2	23.4	-13.0	-7.4	1.1
100	0.7	20.4	13.6	23.2	-14.8	-7.9	1.4
250	0.7	20.1	13.6	23.5	-14.5	-8.9	1.2
500	0.8	19.2	13.1	22.7	-12.8	-12.5	1.4
750	0.7	17.9	12.6	22.6	-11.2	-17.7	1.9
1000	0.7	16.6	12.1	22.8	-9.9	-16.2	2.2
1500	0.8	14.2	13.8	24.1	-8.3	-9.4	2.0
2000	0.9	13.0	14.5	26.6	-8.3	-7.9	1.7
2600	0.9	13.6	14.7	29.1	-16.0	-19.3	2.2

**Table 5.1 TL0374J-EVB-D1 Electrical Characteristics Summary**

## 6. TL0374J-EVB-D1 Test Results

All the tests are carried out at room temperature.

### 6.1. S parameters

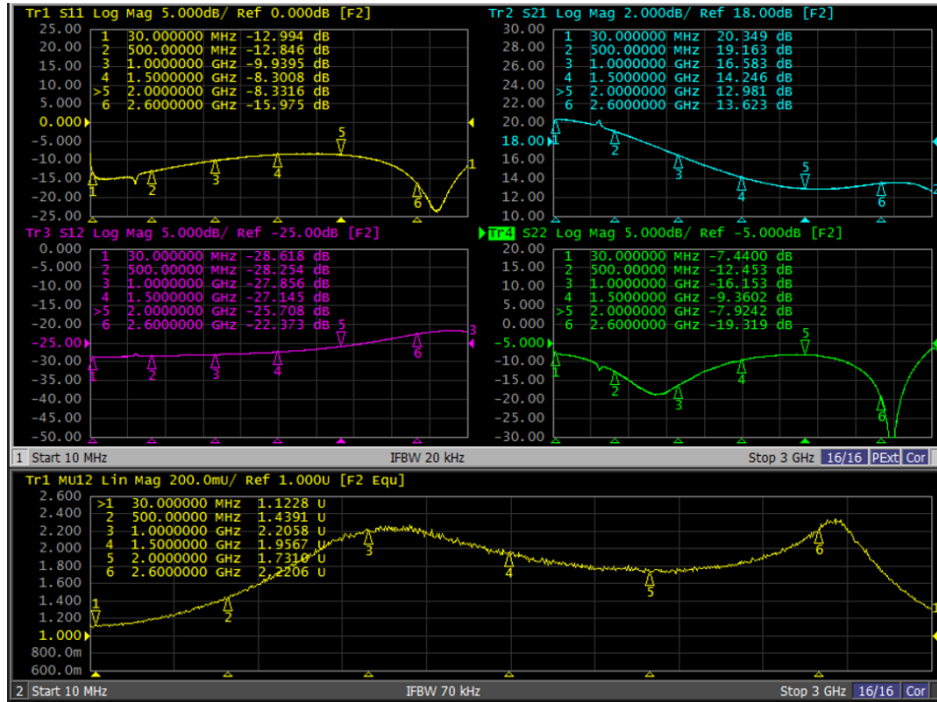
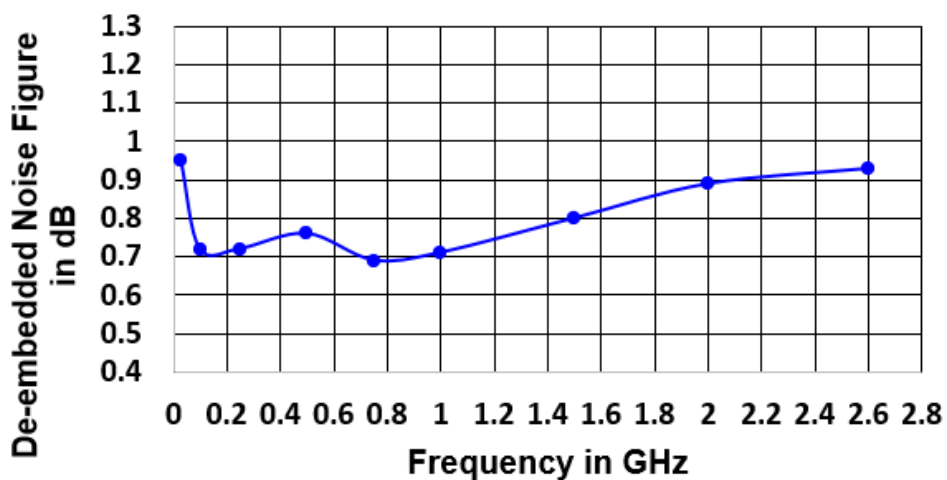

Figure 6.1.1. S parameters of TL0374J-EVB-D1

### 6.2. De-embedded Noise Figure



**\*\* Note:** Trace loss is around 0.02-0.06 dB. So SMA-SMA NF will lie between 0.7 dB to 1.0 dB.

Figure 6.2.1. De-embedded Noise Figure of TL0374J-EVB-D1

### 6.3. Large Signal Test Results

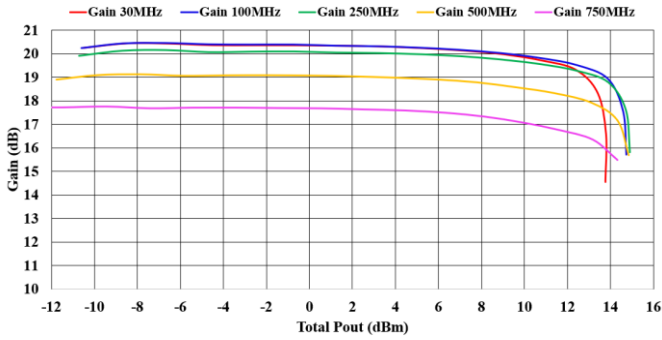

**Figure 6.3.1. Gain Vs Pout of TL0374J-EVB-D1 [30-750 MHz]**

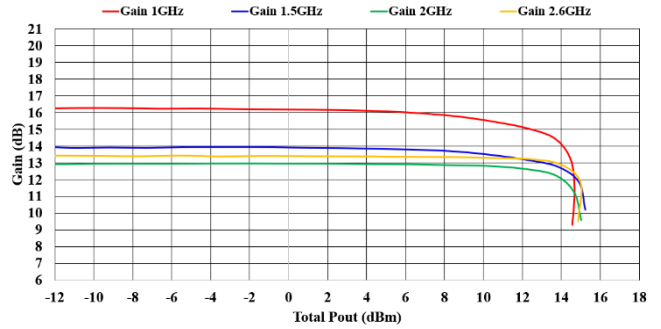

**Figure 6.3.2. Gain Vs Pout of TL0374J-EVB-D1 [1-2.6GHz]**

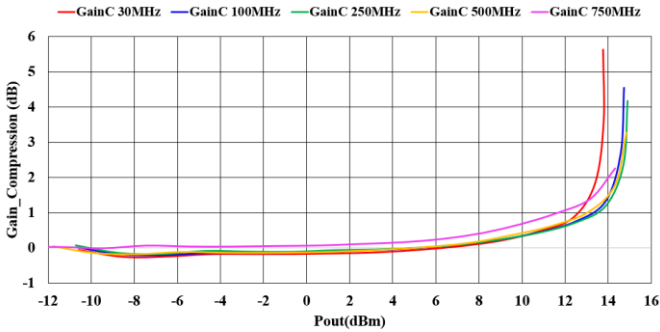

**Figure 6.3.3. Gain compression Vs Pout of TL0374J-EVB-D1 [30-750 MHz]**

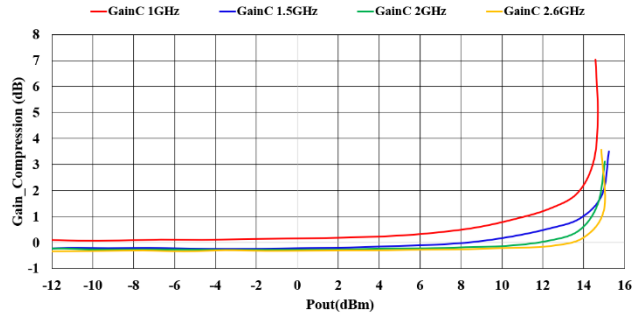

**Figure 6.3.4. Gain compression Vs Pout of TL0374J-EVB-D1 [1-2.6 GHz]**

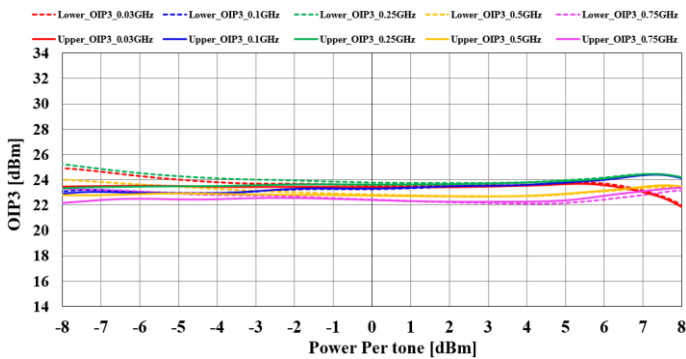

**Figure 6.3.5. Output 3<sup>rd</sup> Order Intercept Point of TL0374J-EVB-D1 [30-750 MHz]**

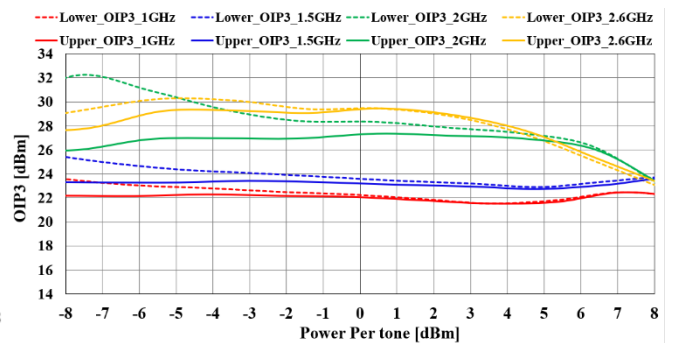

**Figure 6.3.6. Output 3<sup>rd</sup> Order Intercept Point of TL0374J-EVB-D1 [1-2.6 GHz]**

Edition Revision 2.3 - 2024-07-30

Published by

Tagore Tech Inc.

601 W Campus Dr. Ste C1

Arlington Heights, IL 60004, USA

©2024 All Rights Reserved

#### Legal Disclaimer

The information provided in this document shall in no event be regarded as a guarantee of conditions or characteristics. Tagore Tech assumes no responsibility for the consequences of the use of this information, nor for any infringement of patents or of other rights of third parties which may result from the use of this information. No license is granted by implication or otherwise under any patent or patent rights of Tagore Tech. The specifications mentioned in this document are subject to change without notice.

#### Information

For further information on technology, delivery terms and conditions and prices, please contact Tagore Tech: [support@tagoretech.com](mailto:support@tagoretech.com).