

# TL0375J

2.0 – 5.0 GHz GaAs Ultra Low Noise Amplifier

**Application Note: TL0375J EVB B**

## Application Note

3700 MHz~4200 MHz

5.0 V, 60 mA

Rev-2.1

## List of Contents

- 1 General Description
- 2 TL0375J-EVB-B Board Details
- 3 TL0375J -EVB-B Bill of Material
- 4 TL0375J -EVB-B Biasing sequence
- 5 TL0375J -EVB-B Board Measurement Summary
- 6 TL0375J -EVB-B Board Measurement Results

## 1. General Description

The TL0375J is a broadband, ultra-low Noise Amplifier (LNA) providing high gain and linearity. With a simple input and output match, this LNA can be tuned for different frequency bands targeting LTE (small cells and infrastructure) and any other applications requiring low noise, high gain, and linearity. For < 3 GHz frequency band, TL0374J can be considered. The TL0375J is packaged in a compact, low-cost Dual Flat No Lead (DFN) 2 x 2 x 0.75 mm, 8 pin plastic package.

TL0375J-EVB-B is an evaluation board specially tuned for frequency range of 3700 MHz ~ 4200 MHz applications. Its high gain, low noise performance makes it suitable for application of public safety, radar, tactical radio, IoT, Cellular infrastructure, LTE etc.

## 2. TL0375J-EVB-B Board Details

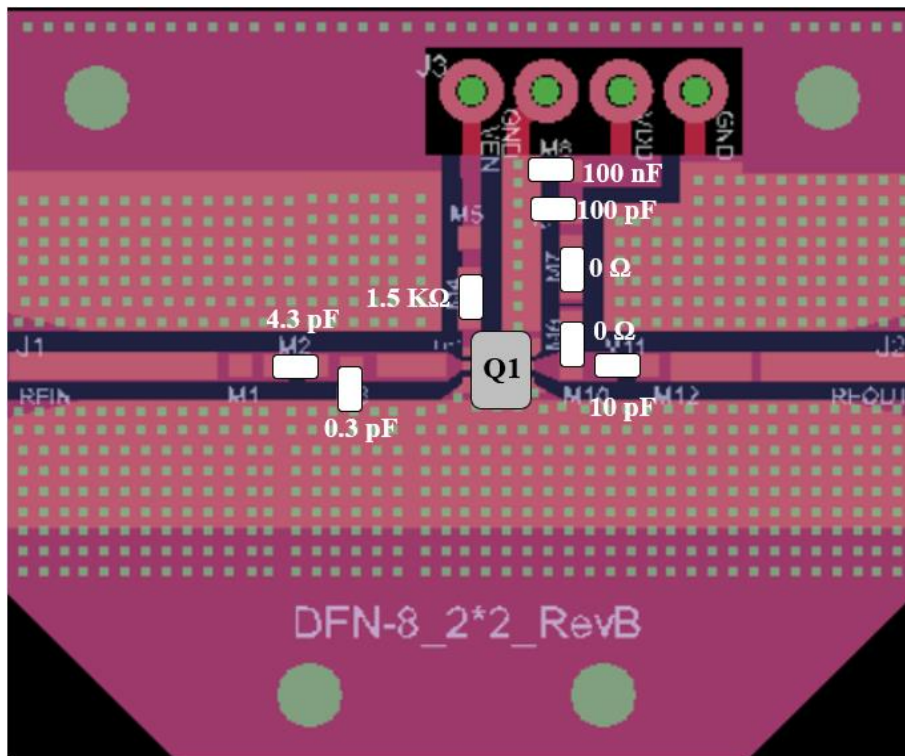
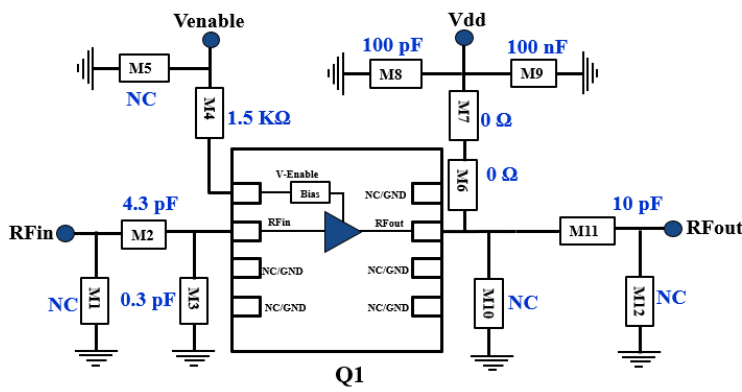

Figure 2.1 TL0375J-EVB-B 3700MHz ~ 4200MHz Schematic and EVB Layout

### 3. TL0375J-EVB-B Bill of Material

Component ID	Value	Manufacturer	Recommended Part Number
M2	4.3 pF	Murata	GJM1555C1H4R3BB01
M3	0.3 pF	Murata	GJM1555C1HR30BB01
M4	1.5 K $\Omega$	Panasonic	ERJ-2RKF1501X
M8	100 pF	AVX	04025A101JAT4A
M9	100 nF	TDK	C1005X7R1H104K050BE
M7	0 $\Omega$	Panasonic	ERJ-2GE0R00X
M6	0 $\Omega$	Panasonic	ERJ-2GE0R00X
M11	10 pF	AVX	04025A100JAT4A
Q1	GaAs LNA	Tagore Tech	TL0375J
PCB		Rogers RO4350B, 20 mils, 1 oz copper	

Table 3.1 TL0375J-EVB-B BOM

### 4. TL0375J-EVB-B Biasing Sequence

Turn ON Device	Turn OFF Device
1. Set Venable to +5 V 2. Set V <sub>DD</sub> to +5 V 3. Device will draw required I <sub>DQ</sub> current 4. Apply RF power	1. Turn RF power off 2. Turn off V <sub>DD</sub> 3. Turn off Venable

Table 4.1 TL0375J-EVB-B Bias and Sequencing

### 5. TL0375J-EVB-B Board Measurement Summary

Frequency (MHz)	EVB Noise Figure (dB)	Gain (dB)	OP1 (dBm)	OIP3(dBm) Fspacing:1 MHz 0dBm Pout/tone	S11 (dB)	S22 (dB)	Mu1
3700	0.6	17.0	20.4	34.3	-15.4	-7.8	1.2
3800	0.6	16.8	20.7	34.0	-15.2	-8.5	1.3
3900	0.6	16.6	20.3	34.2	-14.8	-8.8	1.3
4000	0.6	16.6	20.3	34.1	-14.3	-9.1	1.3
4100	0.7	16.5	20.2	34.1	-14.0	-8.8	1.2
4200	0.7	16.4	20.1	34.1	-13.8	-8.9	1.2

Table 5.1 TL0375J-EVB-B Electrical Characteristics Summary

## 6. TL0375J-EVB-B Test Results

All the tests are carried out at room temperature.

### 6.1. S parameters



Figure 6.1.1. S parameters of TL0375J-EVB-B

### 6.2. EVB Noise Figure

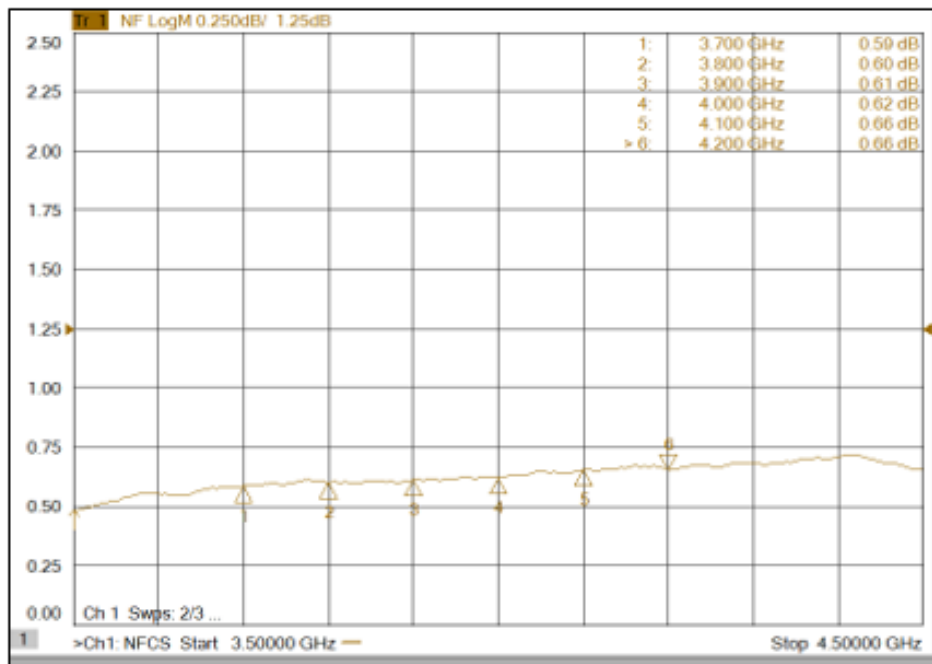
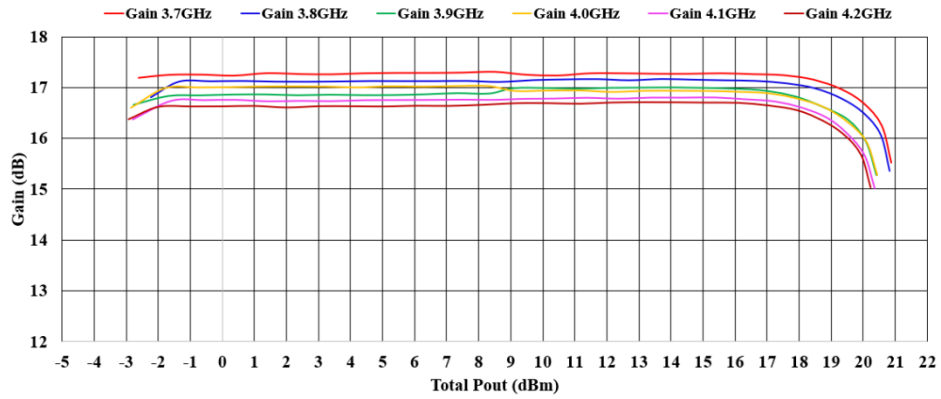
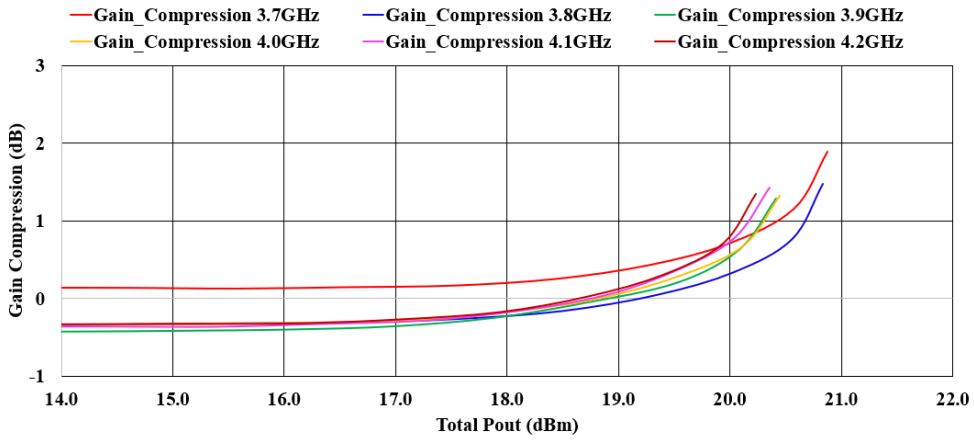

Figure 6.2.1. EVB Noise Figure mode of TL0375J-EVB-B

### 6.3. Large Signal Test Results



**Figure 6.3.1. Gain Vs Pout of TL0375J-EVB-B**



**Figure 6.3.2. Gain compression Vs Pout of TL0375J-EVB-B**

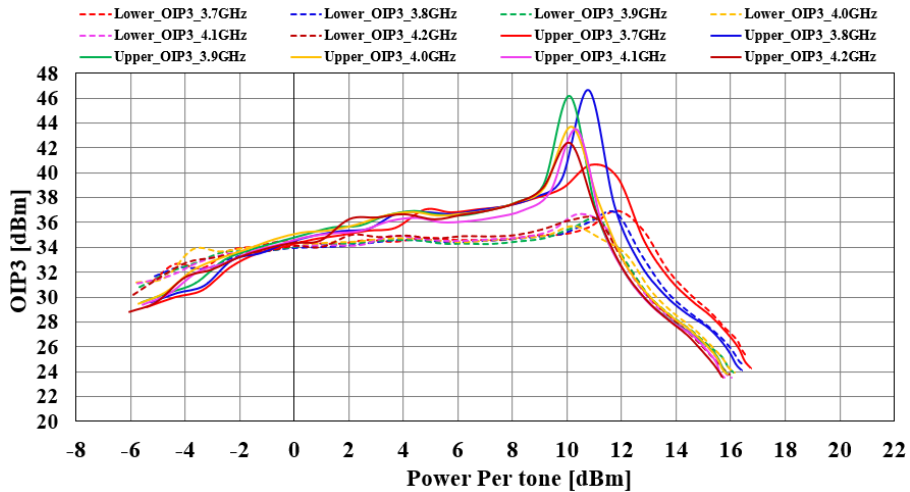

**Figure 6.3.3. Output 3<sup>rd</sup> Order Intercept Point of TL0375J-EVB-B**

Edition Revision 2.1 - 2024-07-30

Published by

Tagore Tech Inc.

601 W Campus Dr. Ste C1

Arlington Heights, IL 60004, USA

©2024 All Rights Reserved

#### Legal Disclaimer

The information provided in this document shall in no event be regarded as a guarantee of conditions or characteristics. Tagore Tech assumes no responsibility for the consequences of the use of this information, nor for any infringement of patents or of other rights of third parties which may result from the use of this information. No license is granted by implication or otherwise under any patent or patent rights of Tagore Tech. The specifications mentioned in this document are subject to change without notice.

#### Information

For further information on technology, delivery terms and conditions and prices, please contact Tagore Tech: [support@tagoretech.com](mailto:support@tagoretech.com).