

TP0310K

27 dBm CW 0.03-3.8GHz GaAs Power LNA

Application Note: TP0310K EVB F

Application Note

2900 MHz~3500 MHz

5.0 V, 130 mA

Rev-2.0

List of Contents

- 1 General Description
- 2 TP0310K-EVB-F Board Details
- 3 TP0310K-EVB-F Bill of Material
- 4 TP0310K-EVB-F Biasing sequence
- 5 TP0310K-EVB-F Board Measurement Summary
- 6 TP0310K-EVB-F Board Measurement Results

1. General Description

The TP0310K is a power Low Noise Amplifier (LNA) providing high gain and linearity. With a simple input and output match, this LNA can be tuned for different frequency bands targeting low noise, high power, and high linearity over 0.03-3.8 GHz frequency band. At 1.85 GHz, the amplifier typically provides 16.5 dB gain, 27.5 dBm OP1, +39 dBm OIP3, and a 1.0 dB noise figure, while drawing 140-160 mA current from a +5 V supply.

TP0310K-EVB-F is an evaluation board specially tuned for frequency range of 2900 MHz~3500 MHz applications. Its application in the areas of Wireless infrastructure, smart cells, cellular repeaters, SDARs Mil/comm radios etc. The TP0310K is packaged in a compact, low-cost Dual Flat No Lead (QFN) 3 x 3 x 0.8 mm, 16 pin plastic package.

2. TP0310K-EVB-F Board Details

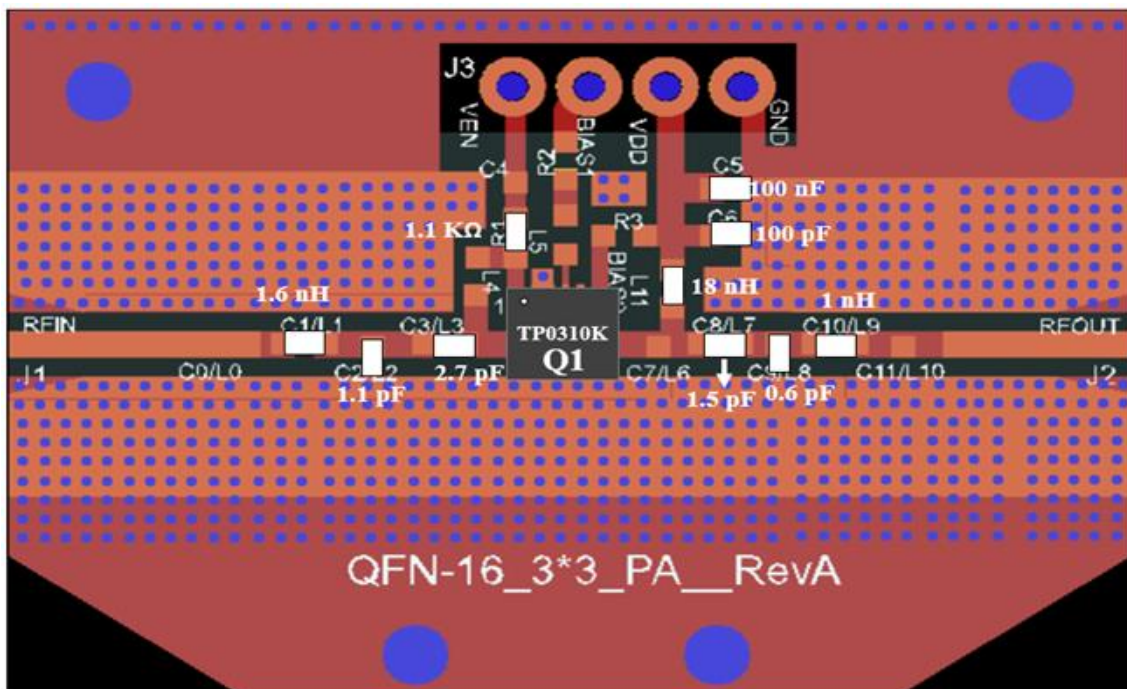
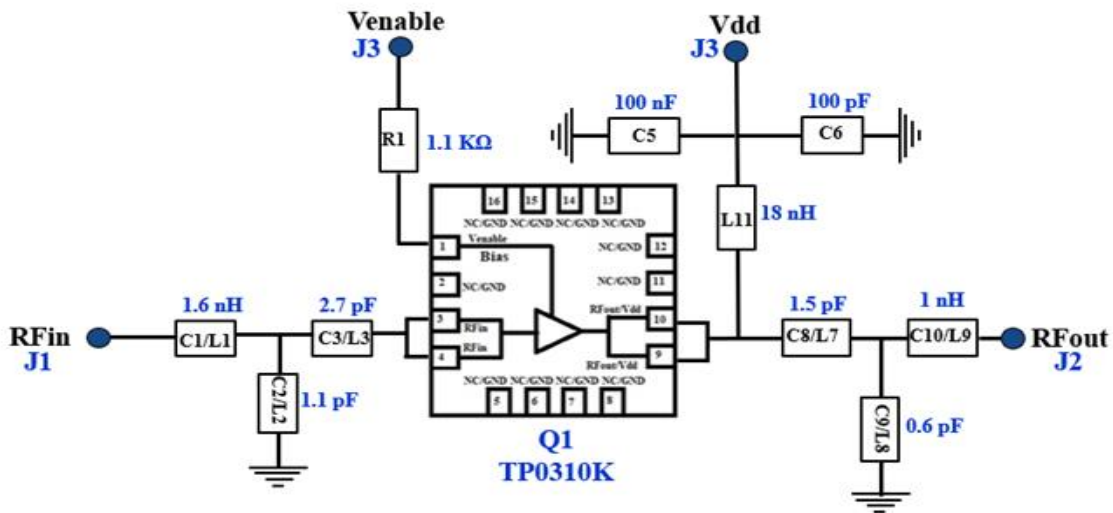

Figure 2.1 TP0310K-EVB-F 2900 MHz ~ 3500 MHz Schematic and EVB Layout

3. TP0310K-EVB-F Bill of Materials

Component ID	Value	Manufacturer	Recommended Part Number
L1	1.6 nH	Coil craft	0603HC-1N6XJRW
C2	1.1 pF	AVX	600S1R1BT250XT
C3	2.7 pF	AVX	600S2R7BT250XT
R1	1.1 K Ω	Panasonic	ERJ-2RKF1111X
C5	100 nF	TDK	C1005X7R1H104K050BE
C6	100 pF	AVX	04025A101JAT4A
C8	1.5 pF	AVX	600S1R5BT250XT
C9	0.6 pF	AVX	600S0R6BT250XT
L9	1 nH	Coil craft	0402HP-1N0XJRW
L11	18 nH	Coil craft	0402HP-18NXGRW
Q1	GaAs LNA	Tagore Tech	TP0310K
PCB		Rogers RO4350B, 20 mils, 1 oz copper	

Table 3.1 TP0310K-EVB-F BOM

4. TP0310K-EVB-F Biasing Sequence

Turn ON Device	Turn OFF Device
1. Set Venable to +5 V 2. Set V_{DD} to +5 V 3. Device will draw required I_{DQ} current 4. Apply RF power	1. Turn RF power off 2. Turn off V_{DD} 3. Turn off Venable

Table 4.1 TP0310K-EVB-F Bias and Sequencing

5. TP0310K-EVB-F Board Measurement Summary

Frequency (MHz)	EVB Noise figure (dB)	Gain(dB)	OP1 (dBm)	OIP3(dBm) 1 MHz tone spacing & 8 dBm power per tone	S11(dB)	S22(dB)	Mu1
2900	1.2	11.7	27.5	38.5	-8.3	-13.2	1.1
3100	0.9	11.8	27.6	37.5	-11.6	-11.8	1.2
3300	0.9	11.8	27.7	38.0	-19.5	-10.3	1.2
3500	1.0	11.4	27.7	38.8	-19.7	-9.8	1.2

Table 5.1 TP0310K-EVB-F Electrical Characteristics Summary

6. TP0310K-EVB-F Test Results

All the tests are carried out at room temperature.

6.1. S parameters

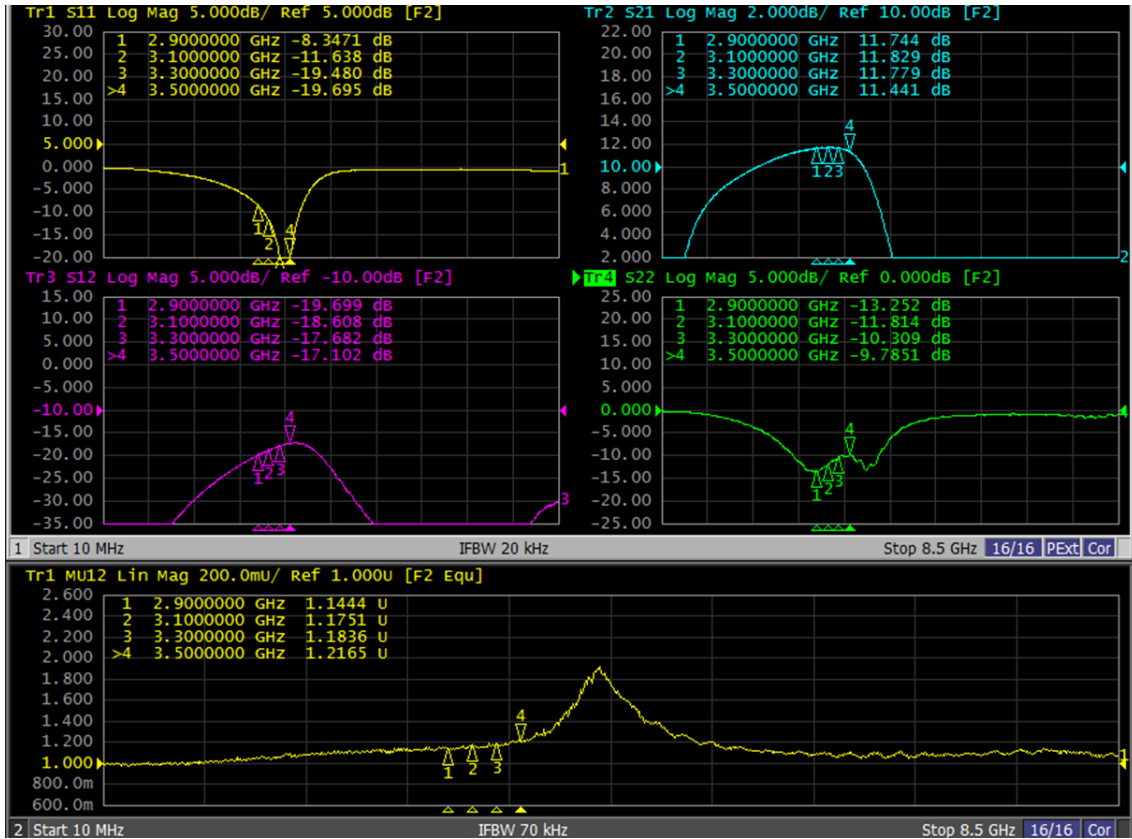

Figure 6.1.1. S parameters of TP0310K-EVB-F

6.2. SMA to SMA Noise Figure

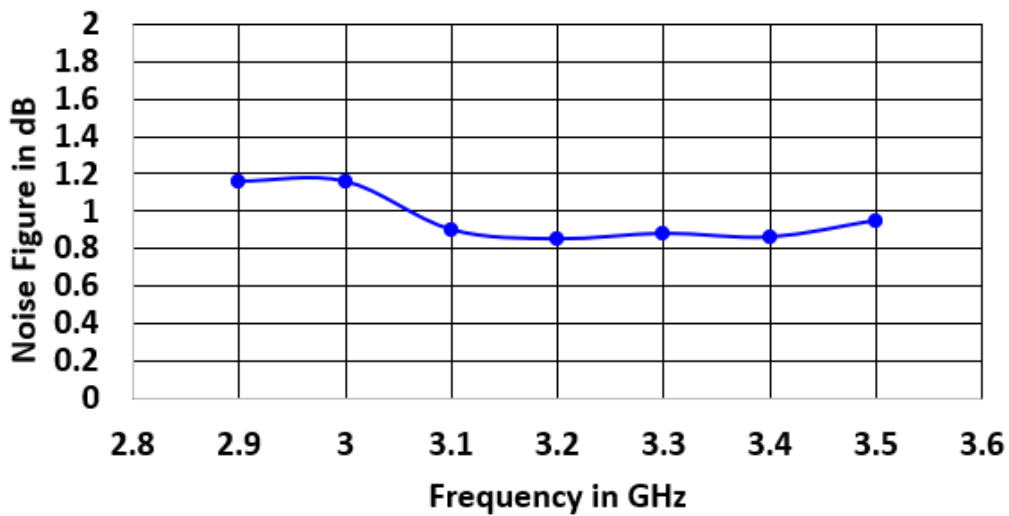

Figure 6.2.1 SMA to SMA NF of TP0310K-EVB-F

6.3. Large Signal Test Results

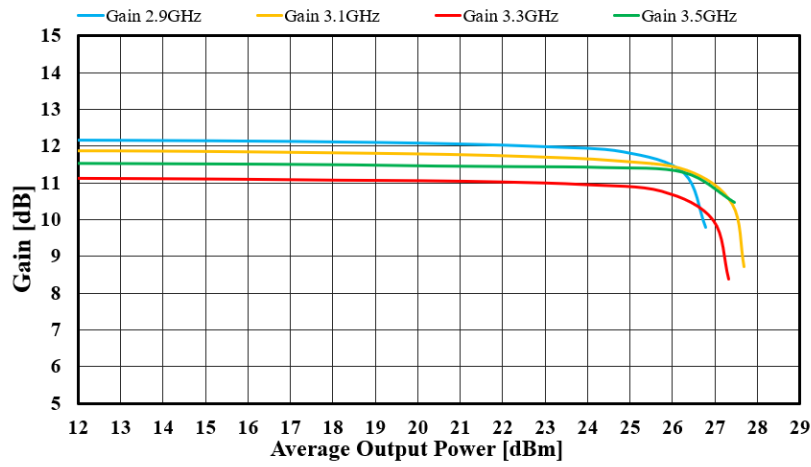

Figure 6.3.1. Gain Vs Pout of TP0310K-EVB-F

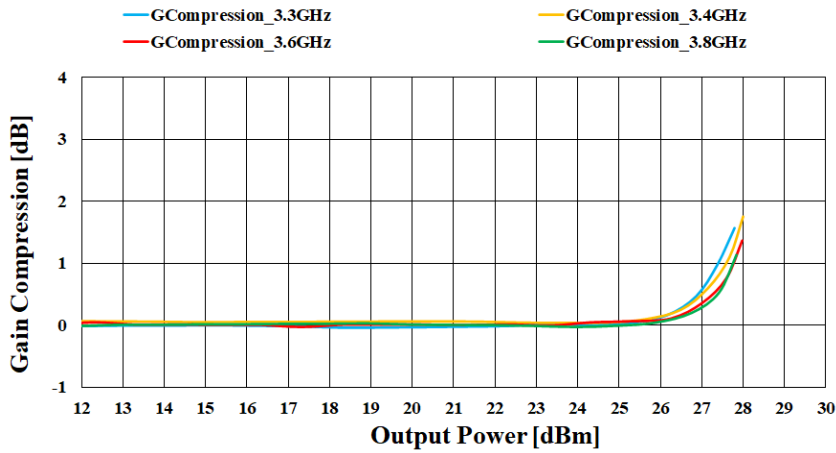

Figure 6.3.2. Gain compression Vs Pout of TP0310K-EVB-F

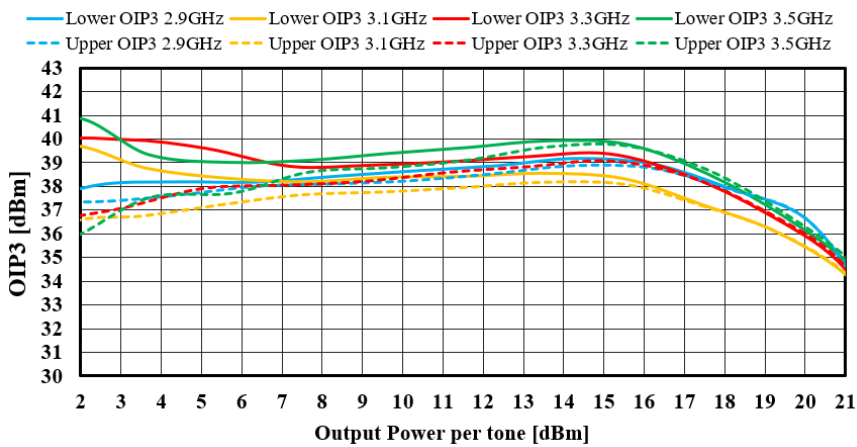

Figure 6.3.3. OIP3 Vs Pout per tone of TP0310K-EVB-F

Edition Revision 2.0 - 2024-07-30

Published by

Tagore Tech Inc.

601 W Campus Dr. Ste C1

Arlington Heights, IL 60004, USA

©2024 All Rights Reserved

Legal Disclaimer

The information provided in this document shall in no event be regarded as a guarantee of conditions or characteristics. Tagore Tech assumes no responsibility for the consequences of the use of this information, nor for any infringement of patents or of other rights of third parties which may result from the use of this information. No license is granted by implication or otherwise under any patent or patent rights of Tagore Tech. The specifications mentioned in this document are subject to change without notice.

Information

For further information on technology, delivery terms and conditions and prices, please contact Tagore Tech: support@tagoretech.com.