

TS7321FK - 20W CW Power GaN Broadband RF Switch SPDT

1.0 Features

- Low insertion loss: 0.35dB @ 800MHz
- High isolation: 45dB @ 800MHz
- High peak power handling capability
- No external DC blocking capacitors on RF lines
- 41dBm CW hot switching capability
- All RF ports OFF state
- Versatile 2.6-5.5V power supply
- Operating frequency: 10MHz to 6GHz

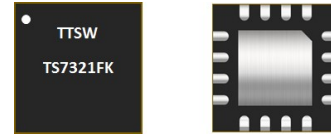

Figure 1 Device Image
(16 Pin 3×3×0.8mm QFN Package)

2.0 Applications

- Private mobile radio handsets
- Public safety handsets
- Cellular infrastructure
- Small cells
- LTE relays and microcells
- Satellite terminals



**RoHS/REACH/Halogen Free
Compliance**

3.0 Description

The TS7321FK is a symmetrical reflective Single Pole Dual Throw (SPDT) switch designed for broadband, high peak power switching applications. Its broadband behavior from 10MHz to 6GHz frequencies makes the TS7321FK an excellent switch for all applications requiring low insertion loss, high isolation and high linearity within a small package size.

The TS7321FK is packaged into a compact Quad Flat No lead (QFN) 3x3mm 16 leads plastic package.

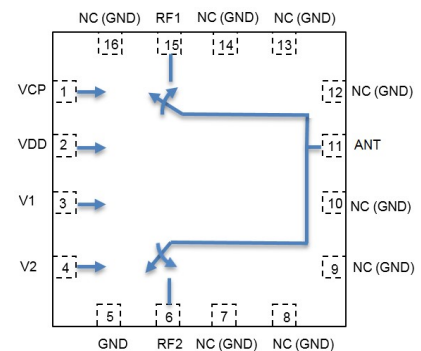

Figure 2 Function Block Diagram
(Top View)

4.0 Ordering Information

Table 1 Ordering Information

Base Part Number	Package Type	Form	Qty	Reel Diameter	Reel Width	Orderable Part Number
TS7321FK	16 Pin 3×3×0.8mm QFN	Tape and Reel	3000	13" (330mm)	18mm	TS7321FKMTRPBF
Evaluation Board						TS7321FK-EVB

5.0 Pin Description

Table 2 Pin Definition

Pin Number	Pin Name	Description
1	VCP	Internal charge pump voltage output. Connect a 1nF capacitor to GND on this pin to improve switching time.
2	VDD	DC power supply
3	V1	Switch control input 1
4	V2	Switch control input 2
6	RF2	RF port 2
5,7,8,9,10,12,13,14,16	NC	No internal connection, Can be grounded
11	ANT	Antenna port
15	RF1	RF port 1

Note: The backside ground (thermal) pad of the package must be grounded directly to the ground plane of PCB with multiple vias to ensure proper operation and thermal management.

6.0 Absolute Maximum Ratings

Table 3 Absolute Maximum Ratings @ $T_A=+25^{\circ}\text{C}$ Unless Otherwise Specified

Parameter	Symbol	Value	Unit
Electrical Ratings			
Power Supply Voltage	VDD	2.6 to 5.5	V
Storage Temperature Range	T_{st}	-55 to +125	$^{\circ}\text{C}$
Operating Temperature Range	T_{op}	-40 to +85	$^{\circ}\text{C}$
Maximum Junction Temperature	T_J	+140	$^{\circ}\text{C}$
RF Input Power CW, 800MHz, $T_J=+85^{\circ}\text{C}$	RFx	43	dBm
RF Input Power CW, > 5GHz, $T_J=+85^{\circ}\text{C}$	RFx	41	dBm
Thermal Ratings			
Thermal Resistance (junction-to-case) – Bottom side	$R_{\theta JC}$	25	$^{\circ}\text{C}/\text{W}$
Thermal Resistance (junction-to-top)	$R_{\theta JT}$	≤ 39	$^{\circ}\text{C}/\text{W}$
Soldering Temperature	T_{SOLD}	260	$^{\circ}\text{C}$
ESD Ratings			
Human Body Model (HBM)	Level 1B	500 to <1000	V
Charged Device Model (CDM)	Level C3	≥ 1000	V
Moisture Rating			
Moisture Sensitivity Level	MSL	1	-

Attention:

Maximum ratings are absolute ratings. Exposure to absolute maximum rating conditions for extended periods may affect device reliability. Exceeding one or a combination of the absolute maximum ratings may cause permanent and irreversible damage to the device and/or to surrounding circuit.

7.0 Electrical Specifications

Table 4 Electrical Specifications @ $T_A=+25^{\circ}\text{C}$ Unless Otherwise Specified; $V_{DD}=+2.7\text{V}$; 50Ω Source/Load.

Parameter	Condition	Minimum	Typical	Maximum	Unit
Operating Frequency		10		6000	MHz
Insertion Loss, RFx	400MHz		0.30		dB
	800MHz		0.35	0.45	
	1.95GHz		0.40	0.60	
	2.6GHz		0.45	0.70	
	6.0GHz		0.90		
Isolation ANT-RFx	400MHz		50		dB
	800MHz	40	45		
	1.95GHz	30	35		
	2.6GHz	27	32		
	6.0GHz		17		
Return Loss ANT-RFx	400MHz		25		dB
	800MHz		25		
	1.95GHz		25		
	2.6GHz		25		
	6.0GHz		13		
H2	800MHz, Pin=35dBm		-46		dBm
H3	800MHz, Pin=35dBm		-46		dBm
IIP3	800MHz		73		dBm
P0.1dB ^[1]	0.1dB compression point, 800MHz	43	44		dBm
Peak Power Handling ^[2]	800MHz, pulsed power		47		dBm
Switching Time	50% ctrl to 10/90% of the RF value is settled. C1=1nF (refer to Figure 3)		0.8		μs
Control Voltage	Power supply VDD	2.6	3.3	5.5	V
	All control pins high, V_{ih}	1.0	3.3	5.25	V
	All control pins low, V_{il}	-0.3		0.5	V
Control Current	All control pins low, I_{il}		0		μA
	All control pins high, I_{ih}			7.5	μA
Current Consumption, IDD	Active mode		160	200	μA

Note:

[1] P0.1dB is a figure of merit.

[2] 1% duty cycle and $10\mu\text{s}$ frame width. Peak P0.1dB.

[3] No external DC blocking capacitors required on RF pins unless DC voltage is applied on a RF pin.

8.0 Switch Truth Table

Table 5 Switch Truth Table

V1	V2	Active RF Path
0	1	All OFF
0	0	ANT-RF1
1	0	ANT-RF2

Attention:

- [1] VDD should be applied first before V1 and V2, otherwise may cause damage to the device.
- [2] There are internal pull-downs to ground on both V1 and V2 control pins, the state at start-up without any control voltage applied will be ANT-RF1 ON.
- [3] If all OFF state is not used, the switch can be operated with single control pin V1.

9.0 Evaluation Board

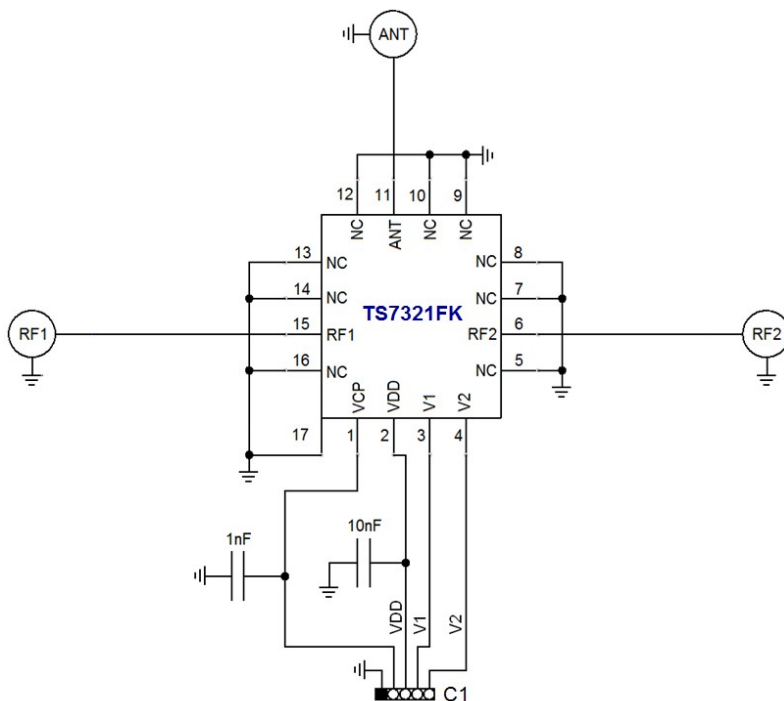

Figure 3 Evaluation Board Schematic

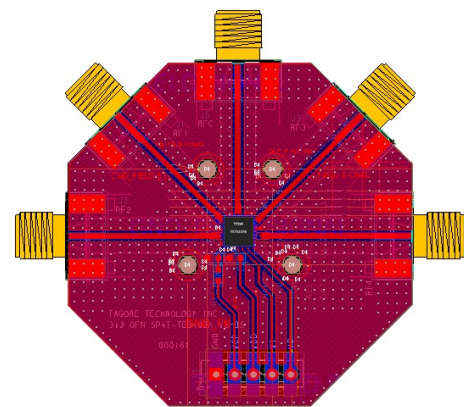

Figure 4 Evaluation Board Image

Attention:

- [1] 17 refers to the center pad of the device.
- [2] The purpose of connection between VCP and connector C1 is to monitor VCP, do not apply external voltage to VCP.

10.0 Typical Characteristics

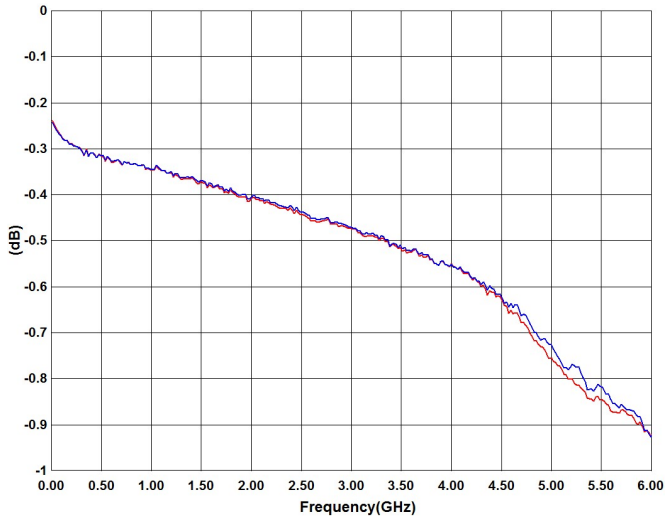

Figure 5 RF1, RF2 Insertion Loss

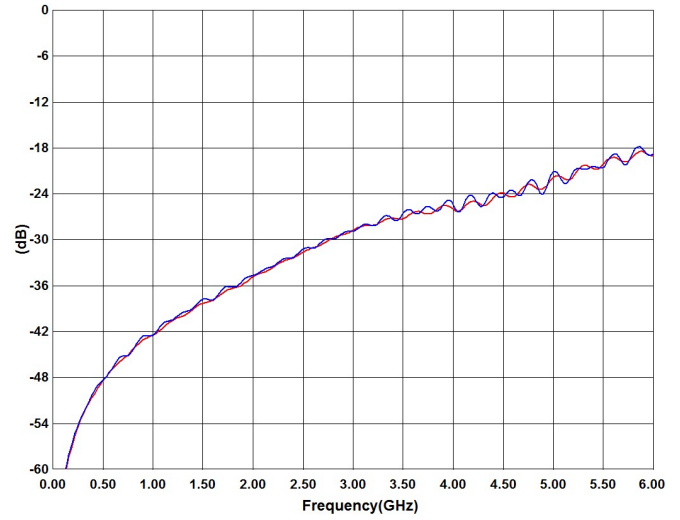

Figure 6 RF1, RF2 Isolation

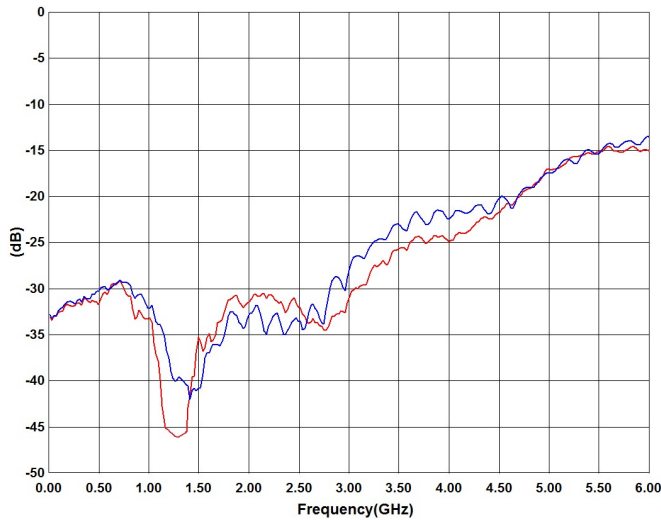

Figure 7 RF1, RF2 Return Loss

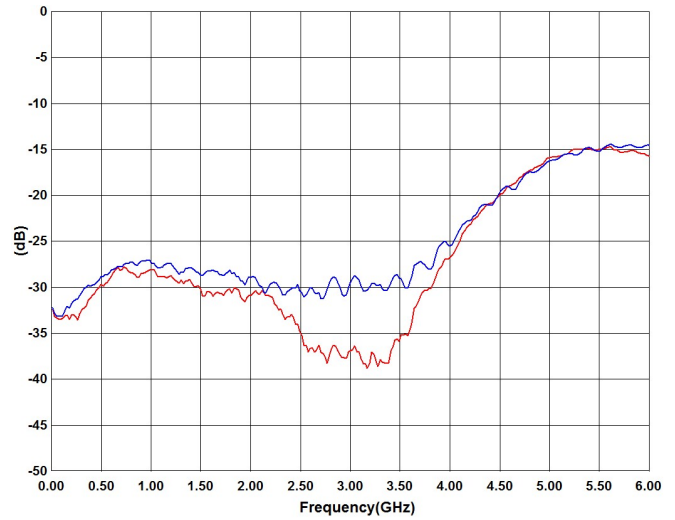

Figure 8 ANT Return Loss

11.0 Device Package Information

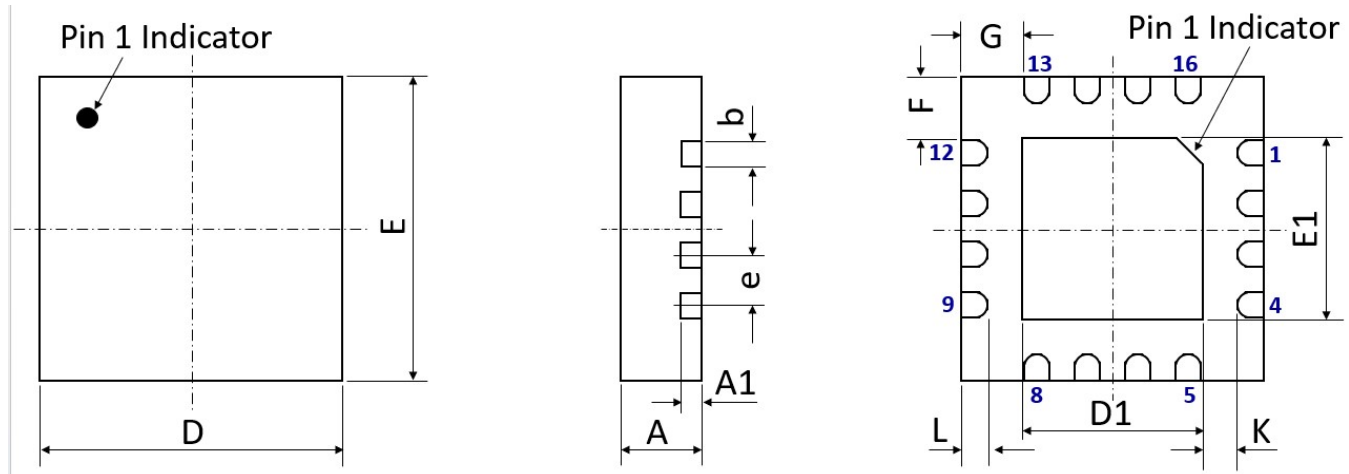

Figure 9 Device Package Drawing
(All dimensions are in mm)

Table 6 Device Package Dimensions

Dimension (mm)	Value (mm)	Tolerance (mm)	Dimension (mm)	Value (mm)	Tolerance (mm)
A	0.80	± 0.05	E	3.00 BSC	± 0.05
A1	0.203	± 0.02	E1	1.70	± 0.05
b	0.25	+0.05/-0.07	F	0.625	± 0.05
D	3.00 BSC	± 0.05	G	0.625	± 0.05
D1	1.70	± 0.05	L	0.25	± 0.05
e	0.50 BSC	± 0.05	K	0.40	± 0.05

Note: Lead finish: Pure Sn without underlayer; Thickness: 7.5 μ m ~ 20 μ m (Typical 10 μ m ~ 12 μ m)

Attention:

Please refer to application notes [TN-001](#) and [TN-002](#) at <http://www.tagoretech.com> for PCB and soldering-related guidelines.

Top-marking specification:

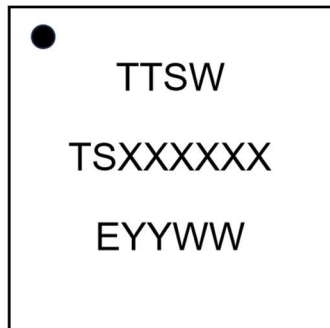

- = Pin 1 indicator
- TTSW = Tagore Technology SWitch
- TSXXXXXX = Part number (8 digits max)
- E = A fixed letter before the date code
- YY = Last two digits of assembly year
- WW = Assembly work week

12.0 PCB Land Design

Guidelines:

- [1] 4 layer PCB is recommended.
- [2] Via diameter is recommended to be 0.2mm to prevent solder wicking inside the vias.
- [3] Thermal vias shall only be placed on the center pad.
- [4] The maximum via number for the center pad is $3(X) \times 3(Y) = 9$.

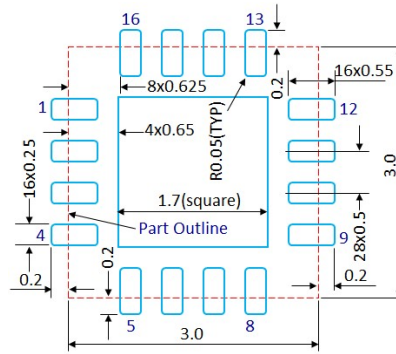

Figure 10 PCB Land Pattern
(Dimensions are in mm)

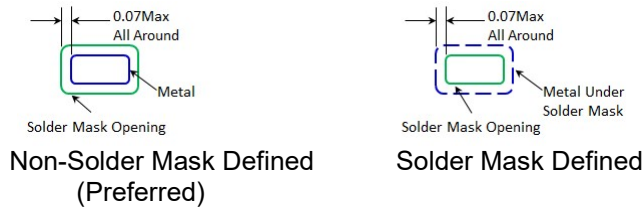

Figure 11 Solder Mask Pattern
(Dimensions are in mm)

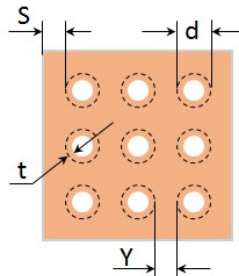

Figure 12 Thermal Via Pattern
(Recommended Values: $S \geq 0.15\text{mm}$; $Y \geq 0.20\text{mm}$; $d = 0.2\text{mm}$; Plating Thickness $t = 25\mu\text{m}$ or $50\mu\text{m}$)

13.0 PCB Stencil Design

Guidelines:

[1] Laser-cut, stainless steel stencil is recommended with electro-polished trapezoidal walls to improve the paste release.

[2] Stencil thickness is recommended to be 125µm.

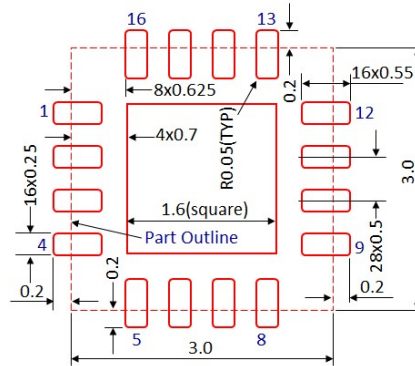

Figure 13 Stencil Openings
(Dimensions are in mm)

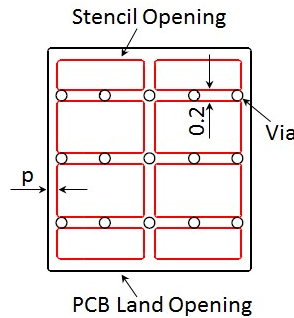

Figure 14 Stencil Openings Shall not Cover Via Areas If Possible
(Dimensions are in mm)

14.0 Tape and Reel Information

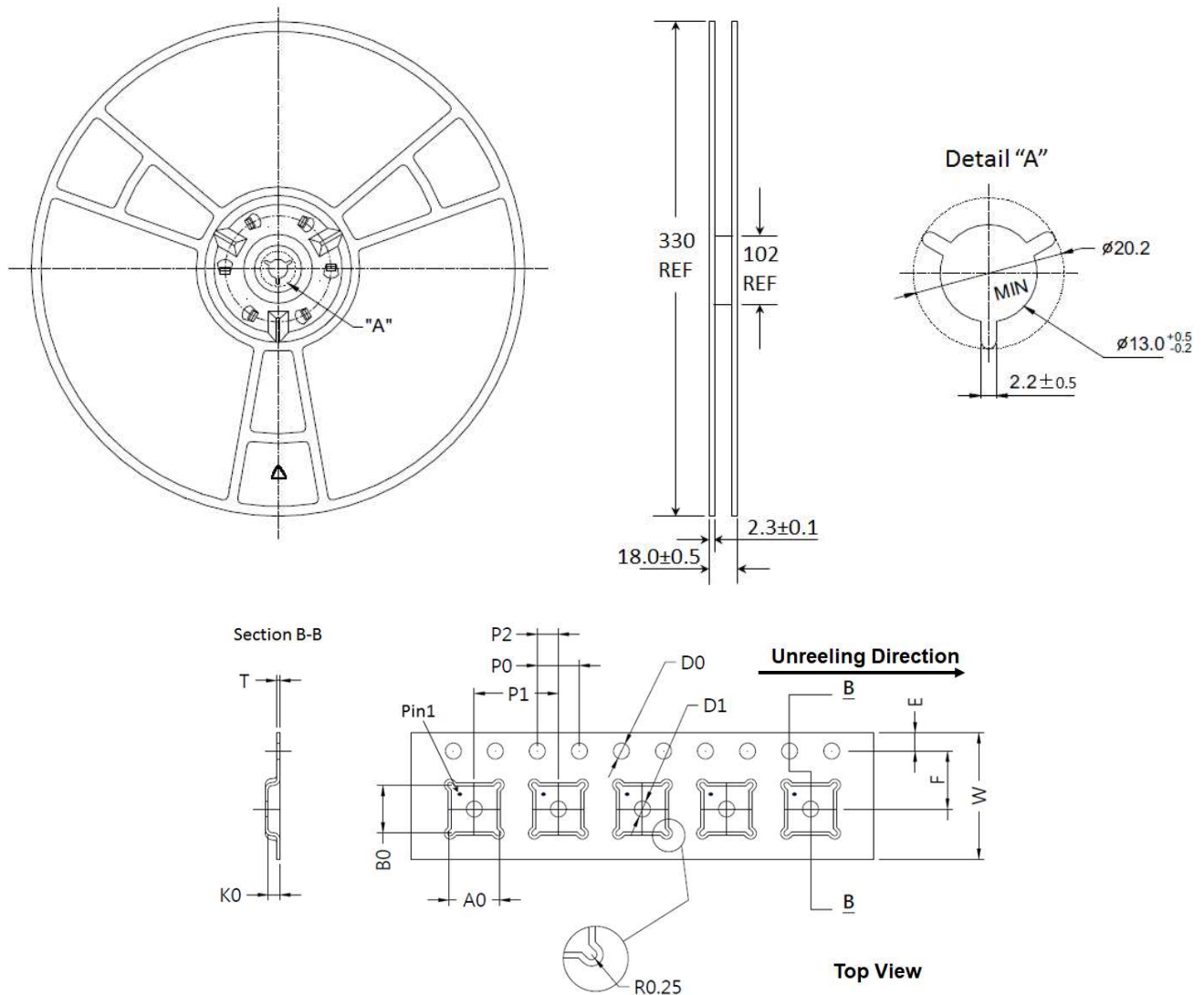

Figure 15 Tape and Reel Drawing

Table 7 Tape and Reel Dimensions

Dimension (mm)	Value (mm)	Tolerance (mm)	Dimension (mm)	Value (mm)	Tolerance (mm)
A0	3.35	±0.10	K0	1.10	±0.10
B0	3.35	±0.10	P0	4.00	±0.10
D0	1.50	+0.10/-0.00	P1	8.00	±0.10
D1	1.50	+0.10/-0.00	P2	2.00	±0.05
E	1.75	±0.10	T	0.30	±0.05
F	5.50	±0.05	W	12.00	±0.30

Edition Revision 2.0 - 2024-09-04

Published by

TagoreTech Inc.
601 Campus Drive, Suite C1
Arlington Heights, IL 60004, USA

©2018 All Rights Reserved

Legal Disclaimer

The information provided in this document shall in no event be regarded as a guarantee of conditions or characteristics. TagoreTech assumes no responsibility for the consequences of the use of this information, nor for any infringement of patents or of other rights of third parties which may result from the use of this information. No license is granted by implication or otherwise under any patent or patent rights of TagoreTech. The specifications mentioned in this document are subject to change without notice.

Information

For further information on technology, delivery terms and conditions and prices, please contact TagoreTech: support@tagoretech.com.