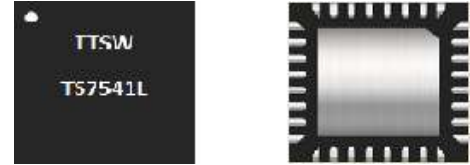


**TS7541L - 50W CW GaN Broadband RF Switch SP4T**

**1.0 Features**

- Low insertion loss: 0.40dB @ 800MHz
- High isolation: 36dB @ 800MHz
- High linear power handling capability
- No external DC blocking capacitors on RF lines
- Versatile 2.6-5.5V power supply



**Figure 1 Device Image**  
(32 Pin 4x4x0.8mm QFN Package)

**2.0 Applications**

- Private mobile radio handsets
- Public safety handsets
- Cellular infrastructure
- Small cells

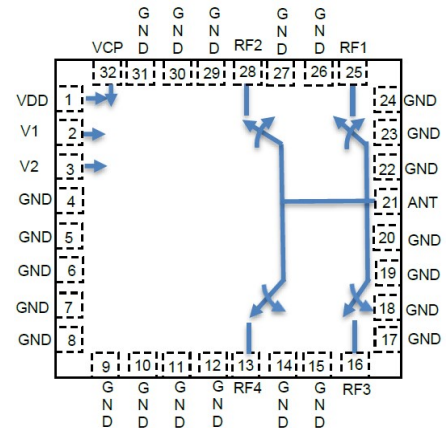


**RoHS/REACH/Halogen Free Compliance**

**3.0 Description**

The TS7541L is a symmetrical reflective Single Pole Four Throws (SP4T) switch designed for broadband, high power switching applications. Its broadband behavior from 30MHz to 1.2GHz frequencies makes the TS7541L an excellent switch for all the applications requiring low insertion loss, high isolation and high linearity within a small package size. Part can also be used below 30MHz with reduced power handling.

The TS7541L is packaged into a compact Quad Flat No lead (QFN) 4x4mm 32 leads plastic package.



**Figure 2 Function Block Diagram**  
(Top View)

**4.0 Ordering Information**

**Table 1 Ordering Information**

Base Part Number	Package Type	Form	Qty	Reel Diameter	Reel Width	Orderable Part Number
TS7541L	32 Pin 4x4x0.8mm QFN	Tape and Reel	3000	13" (330mm)	18mm	TS7541LMTRPBF
Evaluation Board						TS7541L-EVB

## 5.0 Pin Description

**Table 2 Pin Definition**

Pin Number	Pin Name	Description
1	VDD	DC power supply
2	V1	Switch control input 1
3	V2	Switch control input 2
4,5,6,7,8,9,10,11,12,14,15,17,18,19,20,22,23,24,26,27,29,30,31	NC	No internal connection, Can be grounded
13	RF4	RF port 4
16	RF3	RF port 3
21	ANT	Antenna port
28	RF2	RF port 2
25	RF1	RF port 1
32	VCP	Internal charge pump voltage output. Connect a 1nF capacitor to GND on this pin to improve switching time.

**Note: The backside ground (thermal) pad of the package must be grounded directly to the ground plane of PCB with multiple vias to ensure proper operation and thermal management.**

## 6.0 Absolute Maximum Ratings

**Table 3 Absolute Maximum Ratings @ $T_A=+25^{\circ}\text{C}$  Unless Otherwise Specified**

Parameter	Symbol	Value	Unit
<b>Electrical Ratings</b>			
Power Supply Voltage	VDD	2.6 to 5.5	V
Storage Temperature Range	$T_{st}$	-55 to +125	$^{\circ}\text{C}$
Operating Temperature Range	$T_{op}$	-40 to +85	$^{\circ}\text{C}$
Maximum Junction Temperature	$T_J$	+140	$^{\circ}\text{C}$
RF Input Power CW, 250MHz-1.2GHz, $T_c = 85\text{degC}$	RFx	46	dBm
RF Input Power CW, 30MHz -100MHz, $T_c = 85\text{degC}$	RFx	44.5	dBm
<b>Thermal Ratings</b>			
Thermal Resistance (junction-to-case) – Bottom side	$R_{\theta JC}$	10	$^{\circ}\text{C/W}$
Thermal Resistance (junction-to-top)	$R_{\theta JT}$	$\leq 37$	$^{\circ}\text{C/W}$
Soldering Temperature	$T_{SOLD}$	260	$^{\circ}\text{C}$
<b>ESD Ratings</b>			
Human Body Model (HBM)	Level 1B	500 to <1000	V
Charged Device Model (CDM)	Level C3	$\geq 1000$	V
<b>Moisture Rating</b>			
Moisture Sensitivity Level	MSL	1	-

### Attention:

Maximum ratings are absolute ratings. Exposure to absolute maximum rating conditions for extended periods may affect device reliability. Exceeding one or a combination of the absolute maximum ratings may cause permanent and irreversible damage to the device and/or to surrounding circuit.

## 7.0 Electrical Specifications

**Table 4 Electrical Specifications** @T<sub>A</sub>=+25°C Unless Otherwise Specified; VDD=+3.3V; 50Ω Source/Load.

Parameter	Condition	Minimum	Typical	Maximum	Unit
Operating Frequency		30		1200	MHz
Insertion Loss, RFX	400MHz		0.35		dB
	800MHz		0.40	0.50	
Isolation, ANT-RFX	400MHz		43		dB
	800MHz	33	36		
Return Loss, ANT-RFX	400MHz		28		dB
	800MHz		23		
H2	800MHz, Pin=40dBm		-75		dBc
H3	800MHz, Pin=40dBm		-80		dBc
IIP3	800MHz		70		dBm
P0.2dB <sup>[1]</sup>	250MHz – 1.2GHz, CW		47		dBm
P0.2dB <sup>[1]</sup>	100MHz – <250MHz, CW		46		dBm
P0.2dB <sup>[1]</sup>	30MHz – <100MHz, CW		45		dBm
Switching time	50% ctrl to 10/90% of the RF value is settled. C1=1nF (refer to Figure 3)		2.0		μs
Control Voltage	Power supply VDD	2.6	3.3	5.5	V
	All control pins high, V <sub>ih</sub>	1.0	3.3	5.25	V
	All control pins low, V <sub>il</sub>	-0.3		0.5	V
Control Current	All control pins low, I <sub>il</sub>		0		μA
	All control pins high, I <sub>ih</sub>			7.5	μA
Current Consumption, IDD	Active mode		190	220	μA

**Note:** [1] P0.2dB is a figure of merit.

[2] No external DC blocking capacitors required on RF pins unless DC voltage is applied on a RF pin.

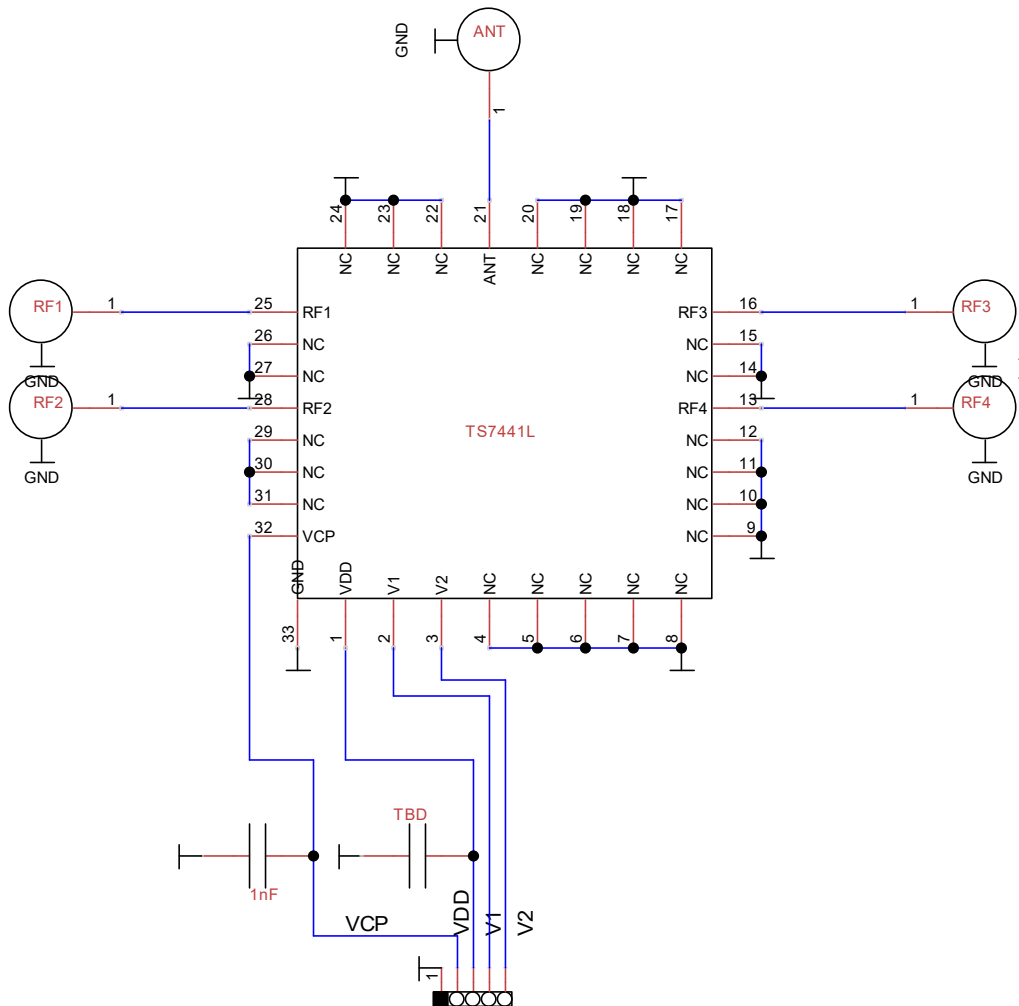
**8.0 Switch Truth Table**

**Table 5 Switch Truth Table**

V1	V2	Active RF Path
0	0	ANT-RF1
1	0	ANT-RF2
0	1	ANT-RF3
1	1	ANT-RF4

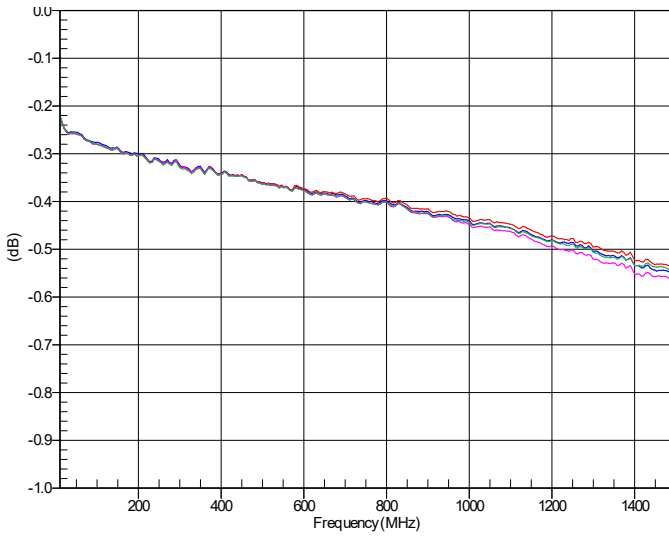
**Attention:** [1] VDD should be applied first before V1 and V2, otherwise may cause damage to the device.  
 [2] There is an internal pull-down to ground on V1 and V2 control pins, therefore the switch state at start-up without any control voltage applied will be ANT-RF1 on by default.

**9.0 Evaluation Board Schematic**

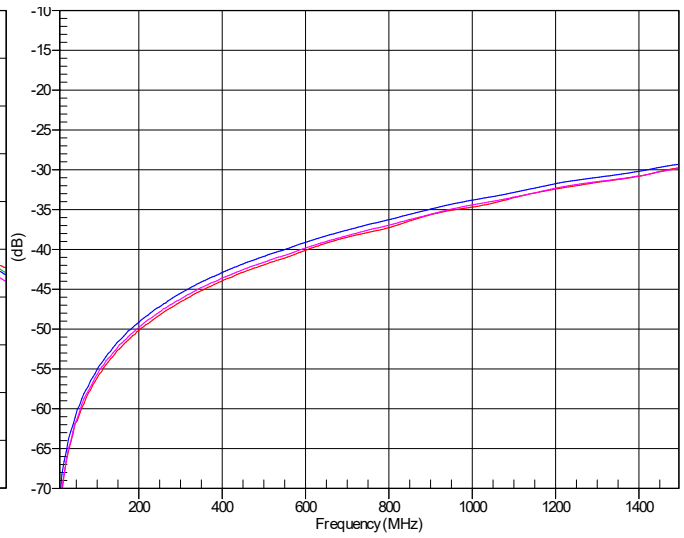


**Figure 3 Evaluation Board Schematic (No Match)**

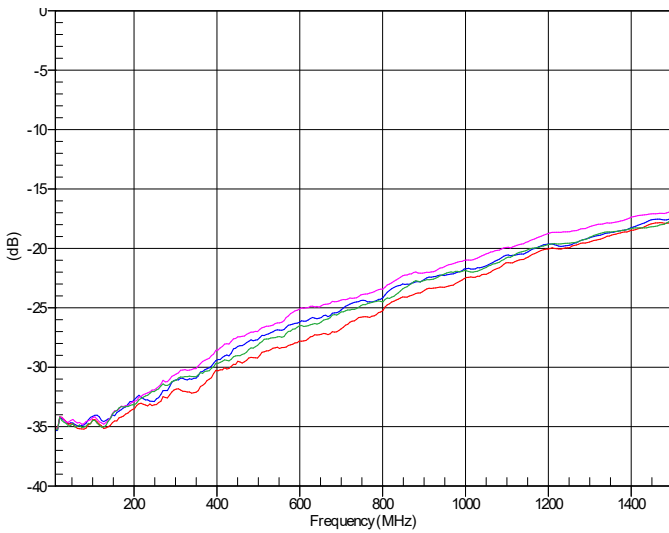
**10.0 Typical Characteristics**



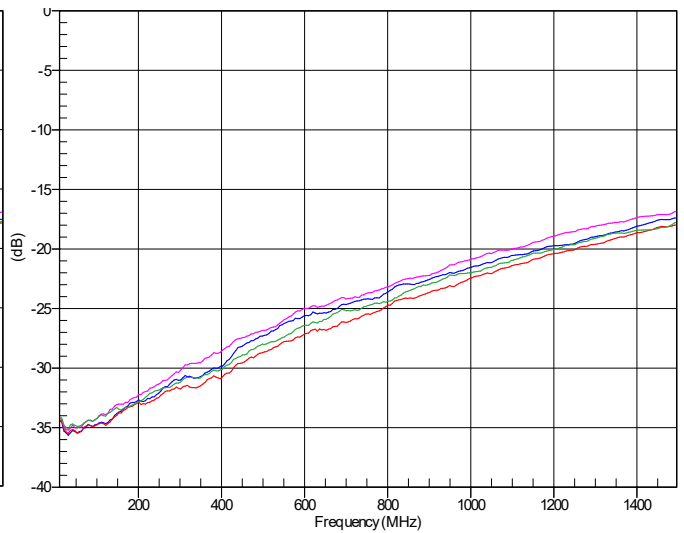
**Figure 4 RF1 to RF4 Insertion Loss**



**Figure 5 RF1 on, RF2 to RF4 Isolation**

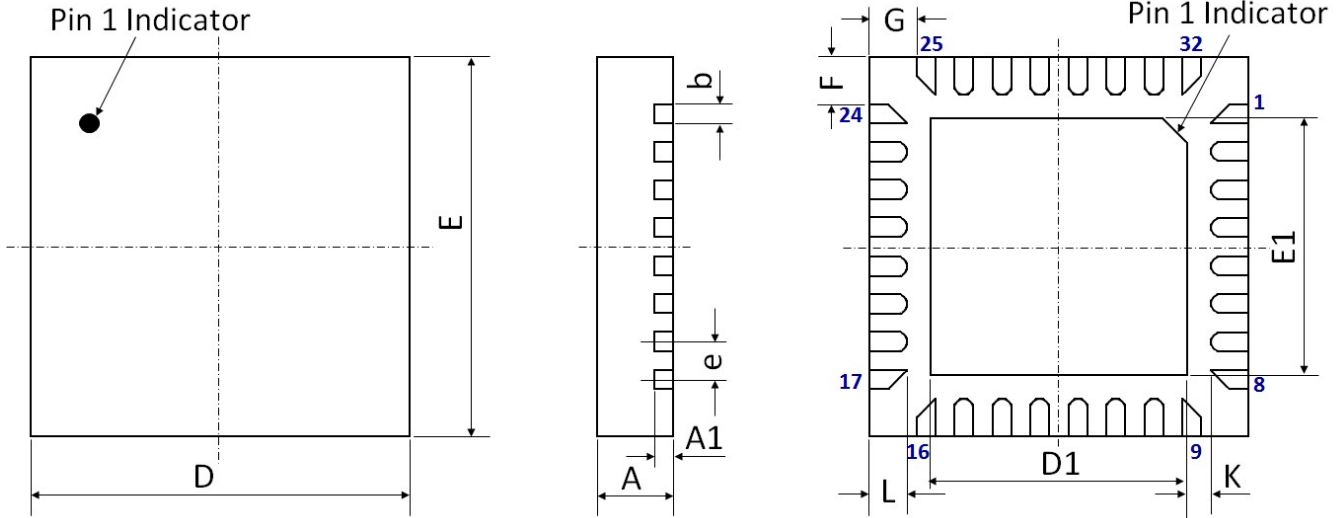


**Figure 6 RF1 to RF4 Return Loss**



**Figure 7 ANT Return Loss**

**11.0 Device Package Information**



**Figure 8 Device Package Drawing**  
(All dimensions are in mm)

**Table 6 Device Package Dimensions**

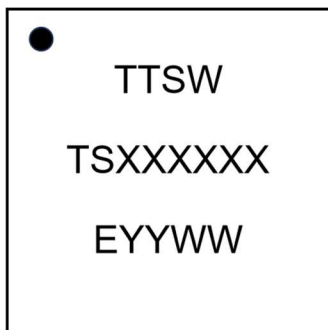
Dimension (mm)	Value (mm)	Tolerance (mm)	Dimension (mm)	Value (mm)	Tolerance (mm)
A	0.80	±0.05	E	4.00 BSC	±0.05
A1	0.203	±0.02	E1	2.70	±0.05
b	0.20	+0.05/-0.07	F	0.50	±0.05
D	4.00 BSC	±0.05	G	0.50	±0.05
D1	2.70	±0.05	L	0.40	±0.05
e	0.40 BSC	±0.05	K	0.25	±0.05

**Note:** Lead finish: Pure Sn without underlayer; Thickness: 7.5µm ~ 20µm (Typical 10µm ~ 12µm)

**Attention:**

Please refer to application notes [TN-001](#) and [TN-002](#) at <http://www.tagoretech.com> for PCB and soldering related guidelines.

**Top-marking specification:**

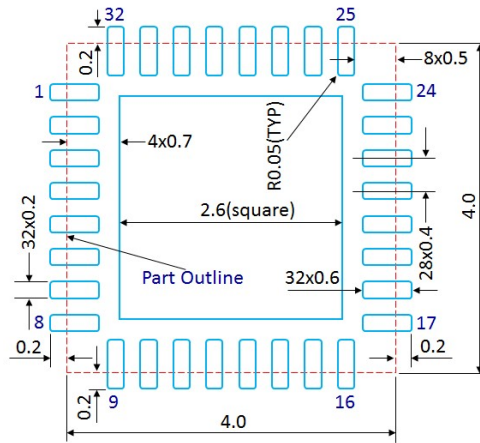


- = Pin 1 indicator
- TTSW = Tagore Technology SWitch
- TSXXXXXX = Part number (8 digits max)
- E = A fixed letter before the date code
- YY = Last two digits of assembly year
- WW = Assembly work week

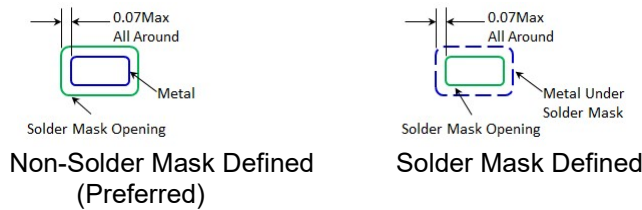
## 12.0 PCB Land Design

### Guidelines:

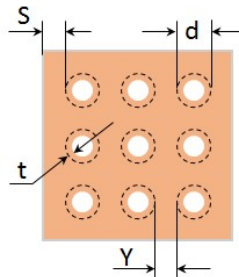
- [1] 4 layer PCB is recommended.
- [2] Via diameter is recommended to be 0.2mm to prevent solder wicking inside the vias.
- [3] Thermal vias shall only be placed on the center pad.
- [4] The maximum via number for the center pad is  $4(X) \times 4(Y) = 16$ .



**Figure 9 PCB Land Pattern**  
(Dimensions are in mm)



**Figure 10 Solder Mask Pattern**  
(Dimensions are in mm)



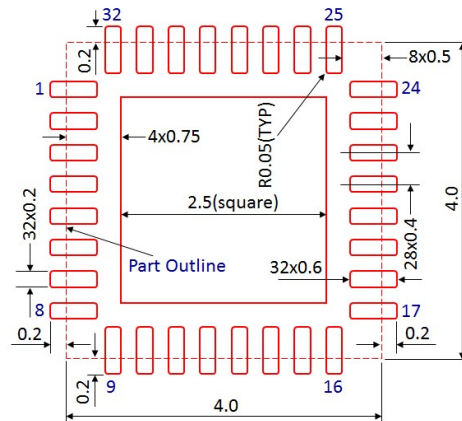
**Figure 11 Thermal Via Pattern**  
(Recommended Values:  $S \geq 0.15\text{mm}$ ;  $Y \geq 0.20\text{mm}$ ;  $d = 0.2\text{mm}$ ; Plating Thickness  $t = 25\mu\text{m}$  or  $50\mu\text{m}$ )

### 13.0 PCB Stencil Design

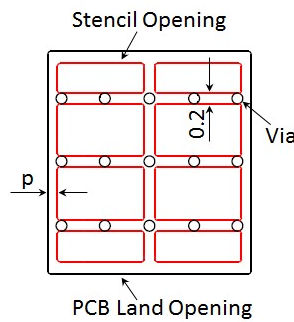
**Guidelines:**

[1] Laser-cut, stainless steel stencil is recommended with electro-polished trapezoidal walls to improve the paste release.

[2] Stencil thickness is recommended to be 125µm.



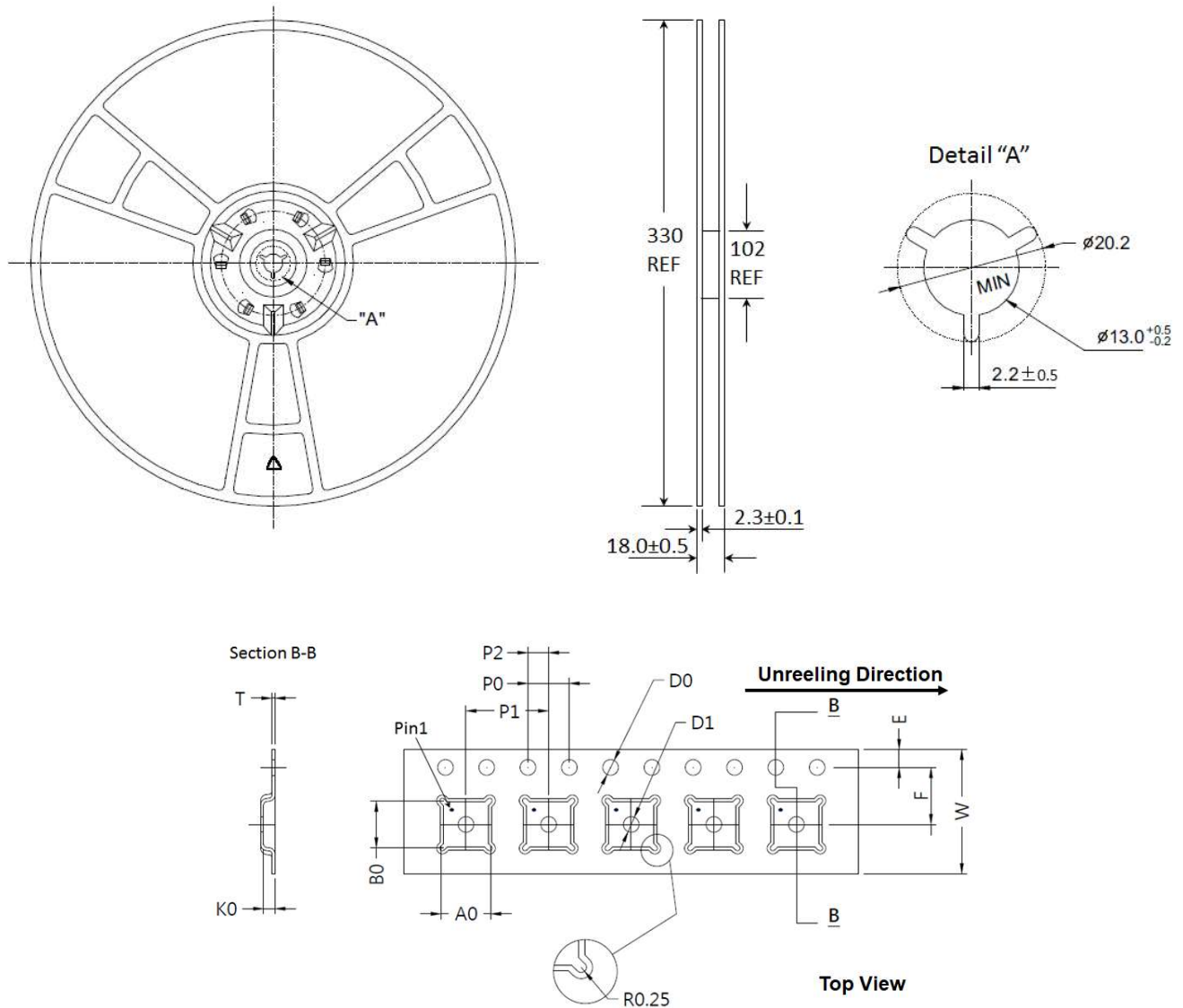
**Figure 12 Stencil Openings**  
(Dimensions are in mm)



**Figure 13 Stencil Openings Shall not Cover Via Areas If Possible**  
(Dimensions are in mm)



**14.0 Tape and Reel Information**



**Figure 14 Tape and Reel Drawing**

**Table 7 Tape and Reel Dimensions**

Dimension (mm)	Value (mm)	Tolerance (mm)	Dimension (mm)	Value (mm)	Tolerance (mm)
A0	4.35	±0.10	K0	1.10	±0.10
B0	4.35	±0.10	P0	4.00	±0.10
D0	1.50	+0.10/-0.00	P1	8.00	±0.10
D1	1.50	+0.10/-0.00	P2	2.00	±0.05
E	1.75	±0.10	T	0.30	±0.05
F	5.50	±0.05	W	12.00	±0.30

**Edition Revision 2.0 - 2024-09-06**

**Published by**

TagoreTech Inc.  
601 Campus Drive, Suite C1  
Arlington Heights, IL 60004, USA

©2018 All Rights Reserved

**Legal Disclaimer**

The information provided in this document shall in no event be regarded as a guarantee of conditions or characteristics. TagoreTech assumes no responsibility for the consequences of the use of this information, nor for any infringement of patents or of other rights of third parties which may result from the use of this information. No license is granted by implication or otherwise under any patent or patent rights of TagoreTech. The specifications mentioned in this document are subject to change without notice.

**Information**

For further information on technology, delivery terms and conditions and prices, please contact TagoreTech: [support@tagoretech.com](mailto:support@tagoretech.com).