

TS86236P – SPDT 200W Average Power Switch 30 MHz to 1.4 GHz
1.0 Features

- Low insertion loss: 0.08dB @ 30 MHz
- High isolation: 70 dB @ 30 MHz, 38 dB @ 1 GHz
- 200W CW Power
- No external DC blocking capacitors on RF lines
- All RF ports OFF state
- Versatile 2.6-5.25V power supply
- Operating frequency: 30 MHz to 1400 MHz

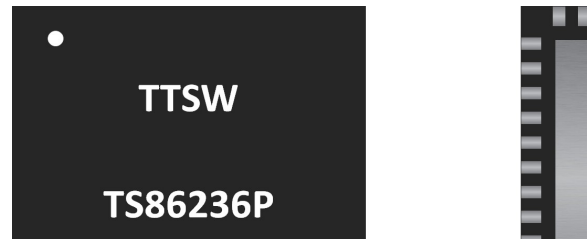

Figure 1 Device Image
 (48 Pin 7×7×0.85mm QFN Package)

2.0 Applications

- Private mobile and military radios
- Public safety handsets
- Cellular infrastructure
- LTE relays and microcells
- Satellite terminals



RoHS/REACH/Halogen Free Compliance

3.0 Description

The TS86236P is a 2nd Generation symmetrical reflective Single Pole Dual Throw (SPDT) switch designed for high power switching applications. The TS86236P covers 30MHz to 1000MHz bandwidth and provides low insertion loss, high isolation, and high linearity within a small package size. The TS86236P is a 200W-CW switch suitable for applications requiring low insertion loss, high isolation, and high linearity.

The TS86236P is packaged into a compact Quad Flat No lead (QFN) 7x7mm 48 leads plastic package.

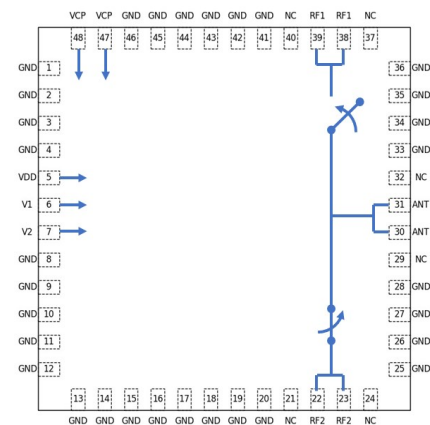

Figure 2 Function Block Diagram
 (Top View)

4.0 Ordering Information

Table 1a Ordering Information

Device Part Number	Package Type	Eval Board Part Number
TS86236P	48 Pin 7×7×0.85mm QFN	TS86236P-EVB

Table 1b Tape and Reel Information

Form	Quantity	Reel Diameter	Reel Width
Tape and Reel	3,000	13" (330mm)	18mm

5.0 Pin Description

Table 2 Pin Definition

Pin Number	Pin Name	Description
47,48	VCP	Short PIN 47 and 48 and connect a 1nF capacitor to GND on this node to improve switching time.
5	VDD	DC power supply
6	V1	Switch control input 1
7	V2	Switch control input 2
1,2,3,4,8,9,10,11,12,13,14,15, 16,17,18,19,20,25,26,27,28, 33,34,35,36,41,42,43,44,45,46	NC	No internal connection, can be grounded
21,24,29,32,37,40	NC	No internal connection. Do not connect to ground
22,23	RF2	RF port 2
30,31	ANT	Antenna port
38,39	RF1	RF port 1
49	GND	Ground thermal pad

Note: The backside ground (thermal) pad of the package must be grounded directly to the ground plane of PCB with multiple vias, and adequate heat sinking must be used to ensure proper operation and thermal management.

6.0 Absolute Maximum Ratings

Table 3 Absolute Maximum Ratings @ $T_A=+25^{\circ}\text{C}$ Unless Otherwise Specified

Parameter	Symbol	Value	Unit
Electrical Ratings			
Power Supply Voltage	VDD	5.5	V
Storage Temperature Range	T_{st}	-55 to +125	$^{\circ}\text{C}$
Operating Temperature Range	T_{op}	-40 to +85	$^{\circ}\text{C}$
Maximum Junction Temperature	T_J	+140	$^{\circ}\text{C}$
Maximum RF CW input power(30MHz)	RFx/ANT	54.5	dBm
Maximum RF CW input power(500MHz)	RFx/ANT	54.5	dBm

Maximum RF peak voltage (30MHz, VSWR 8:1)	RFx/ANT	TBD	V
Thermal Ratings			
Thermal Resistance (junction-to-case) – Bottom side	R _{θJC}	2.5	°C/W
Thermal Resistance (junction-to-top)	R _{θJT}	30	°C/W
Soldering Temperature	T _{SOLD}	260	°C
ESD Ratings			
Human Body Model (HBM)	Level 1B	500 to <1000	V
Charged Device Model (CDM)	Level C3	≥1000	V
Moisture Rating			
Moisture Sensitivity Level	MSL	1	-

Attention:

Maximum ratings are absolute ratings. Exposure to absolute maximum rating conditions for extended periods may affect device reliability. Exceeding one or a combination of the absolute maximum ratings may cause permanent and irreversible damage to the device and/or to surrounding circuit.

7.0 Electrical Specifications

Table 4 Electrical Specifications @ $T_A=+25^{\circ}\text{C}$ Unless Otherwise Specified; $V_{DD}=+3.3\text{V}$; 50Ω Source/Load.

Parameter	Condition	Minimum	Typical	Maximum	Unit
Operating frequency		30		1400	MHz
Insertion loss, RFx	30 MHz		0.08	0.10	dB
	200 MHz		0.11	0.12	
	600 MHz		0.23	0.24	
	1000 MHz		0.36	0.40	
	1300 MHz (matched)		0.23		
Isolation ANT-RFx	30 MHz		70		dB
	200 MHz		54		
	600 MHz		43		
	1000 MHz		38		
	1300 MHz (matched)		33		
Return loss ANT, RFx	30 MHz		41		dB
	200 MHz		31		
	600 MHz		17		
	1000 MHz		14		
	1300 MHz (matched)		23		
Harmonic distortion					
H2	30MHz, Pin=50dBm		88		dBc
H3	30MHz, Pin=50dBm		91		dBc
H2	800MHz, Pin=50dBm		79		dBc
H3	800MHz, Pin=50dBm		85		dBc
Power					
P0.1dB ^[1]	30MHz, CW		54		dBm
P0.1dB ^[1]	915MHz, CW		54		dBm
Ppeak	915MHz, 2% duty cycle, 1.6 ms period		55.5		dBm
Noise					
CP switching Noise	RBW = 1KHz		-140		dBm
Switching Time					
Switching time	50% ctrl to 10/90% of the RF value is settled. CP=1nF to ground on VCP pin.		50	65	μs
DC					
Control voltage	Power Supply VDD	2.6	3.3	5.25	V
	All control pins high, V_{ih}	1.0	3.3	5.25	V
	All control pins low, V_{il}	-0.3		0.5	V
Control current	All control pins low, I_{il}		0		μA
	All control pins high, I_{ih}			7.5	μA
Current consumption, I_{DD}	Active mode (VDD on)		160	260	μA

Note:

[1] P0.1dB is a figure of merit.

[2] No external DC blocking capacitors required on RF pins unless DC voltage is applied on a RF pin.

[3] On control pins, V_{ih} cannot be higher than VDD.

8.0 Switch Truth Table

Table 5 Switch Truth Table

VDD	V2	V1	State
1	0	0	ANT-RF1 ON
1	0	1	ANT-RF2 ON
1	1	0	Open to ANT port. All series FETs are OFF and all shunt FETs are ON.
0	0	0	Short to ANT port. All FETs are ON.

Attention:

- [1] VDD should be applied first before V1 and V2, otherwise may cause damage to the device.
- [2] There are internal pull-downs to ground on both V1 and V2 control pins, the state at start-up without any control voltage applied will be ANT-RF1 ON.
- [3] If all OFF state is not used, the switch can be operated with single control pin V1.

9.0 Schematic and Evaluation Board

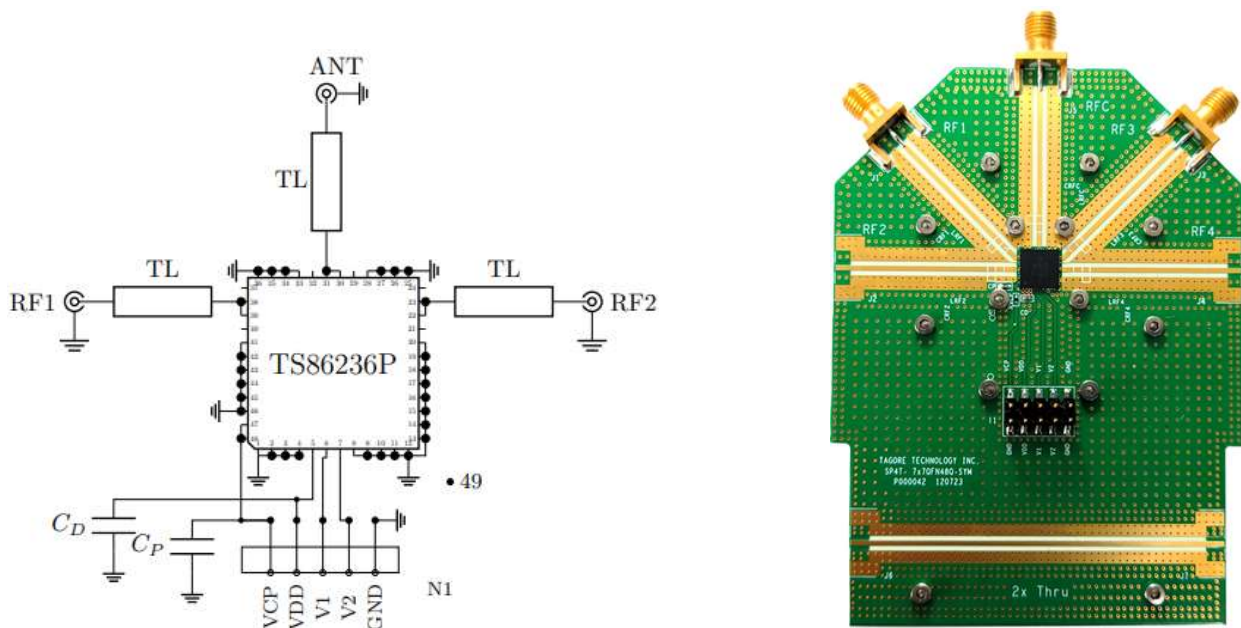

Figure 3 Schematic and Evaluation Board

Attention:

- [1] 49 refers to the center pad of the device. Multiple Plugged through hole vias should be added on this ground pad and adequate heat sinking should be used.
- [2] The purpose of connection between VCP and connector N1 is to monitor VCP, do not apply external voltage to VCP.

10.0 Typical Characteristics – Unmatched

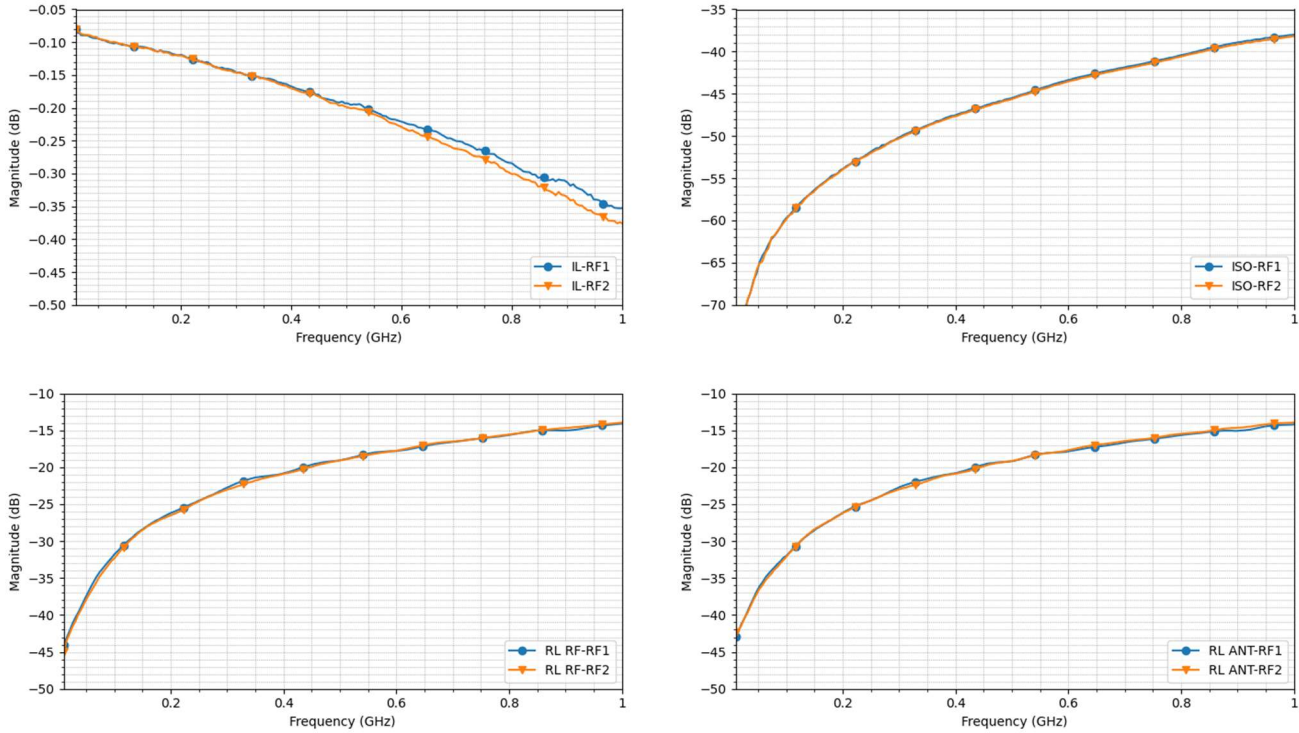

Figure 4a Typical characteristics (Unmatched)

10.2 Typical Characteristics – Matched (800 MHz – 1000 MHz)

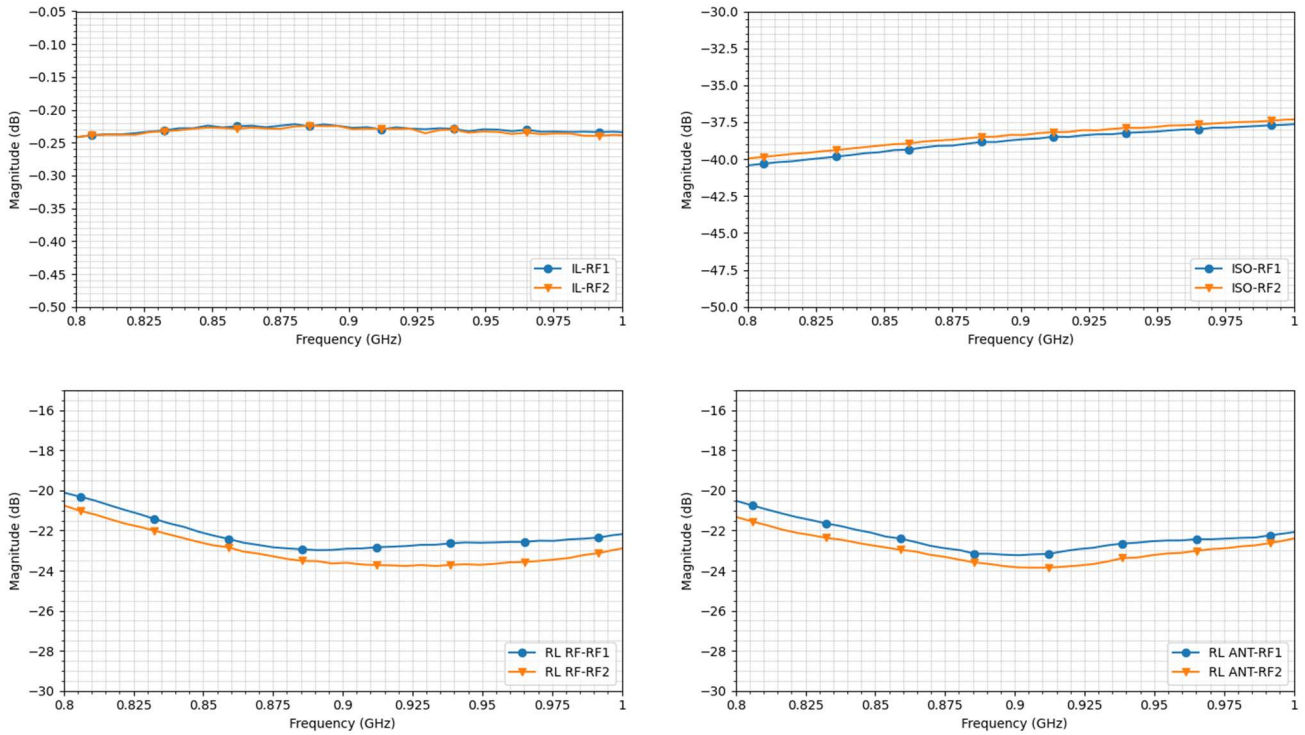

Figure 4b Typical characteristics (800 MHz – 1000 MHz)

10.3 Typical Characteristics – Matched (1200 MHz – 1400 MHz)

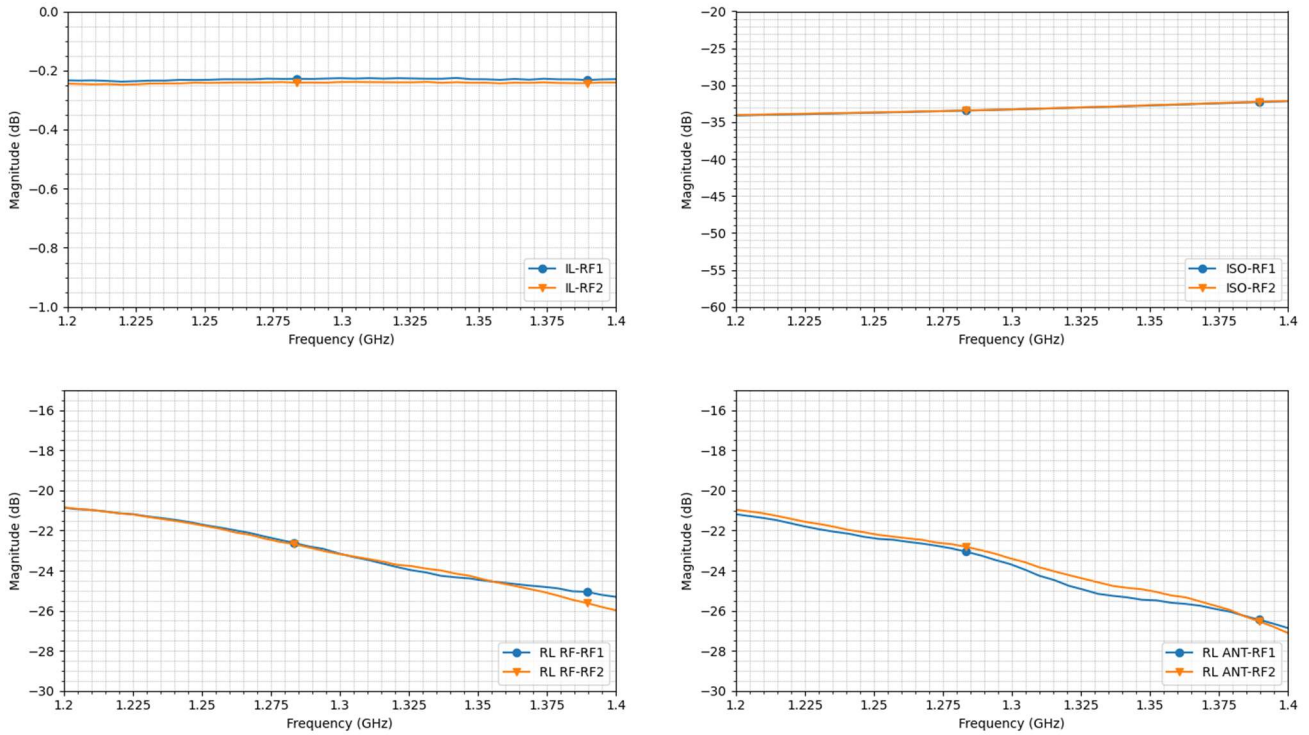

Figure 4c Typical characteristics (1200 MHz – 1400 MHz)

Table 6.1 Bill of Materials – (Unmatched)

Component	Part Number	Description	Notes
C _P	GRM155R71H102KA01D	Ceramic capacitor, 1 nF, 50 V, ±10%.	
C _D	GRM155R71H103KA88	Ceramic capacitor, 10 nF, 50 V, ±15%.	

* For additional details, please contact the Tagore Technology support team.

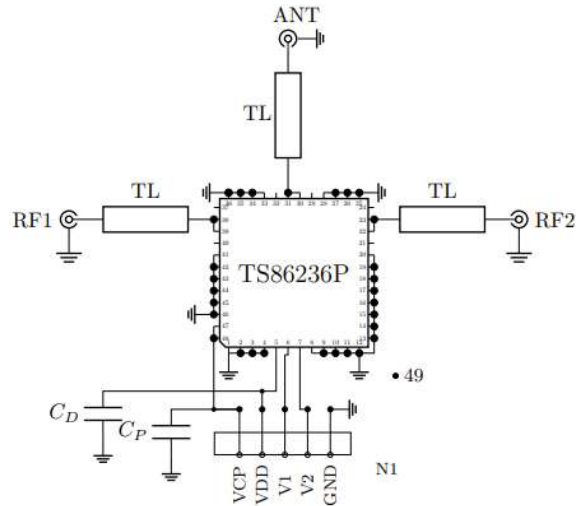

Figure 5a. Unmatched circuit schematic.

Table 6.2 Bill of Materials – Matched (800 MHz – 1000 MHz)

Component	Part Number	Description	Notes
C _P	GRM155R71H102KA01D	Ceramic capacitor, 1 nF, 50 V, ±10%.	
C _D	GRM155R71H103KA88	Ceramic capacitor, 10 nF, 50 V, ±15%.	
L _{1a}	0603DC-18NX_RW	Ceramic core chip inductor, 18 nH, ± 5%.	
L _{2a}	0603DC-18NX_RW	Ceramic core chip inductor, 18 nH, ± 5%.	
T _{1a}	1 mm	PCB transmission line length.	From the IC-reference plane.
T _{2a}	1 mm	PCB transmission line length.	From the IC-reference plane.

* For additional details, please contact the Tagore Technology support team.

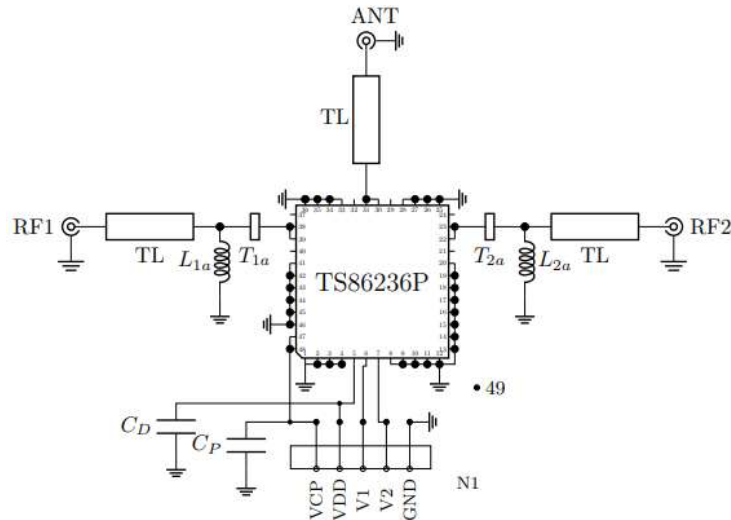

Figure 5b. 10 MHz – 1000 MHz circuit schematic.

11.0 Device Package Information

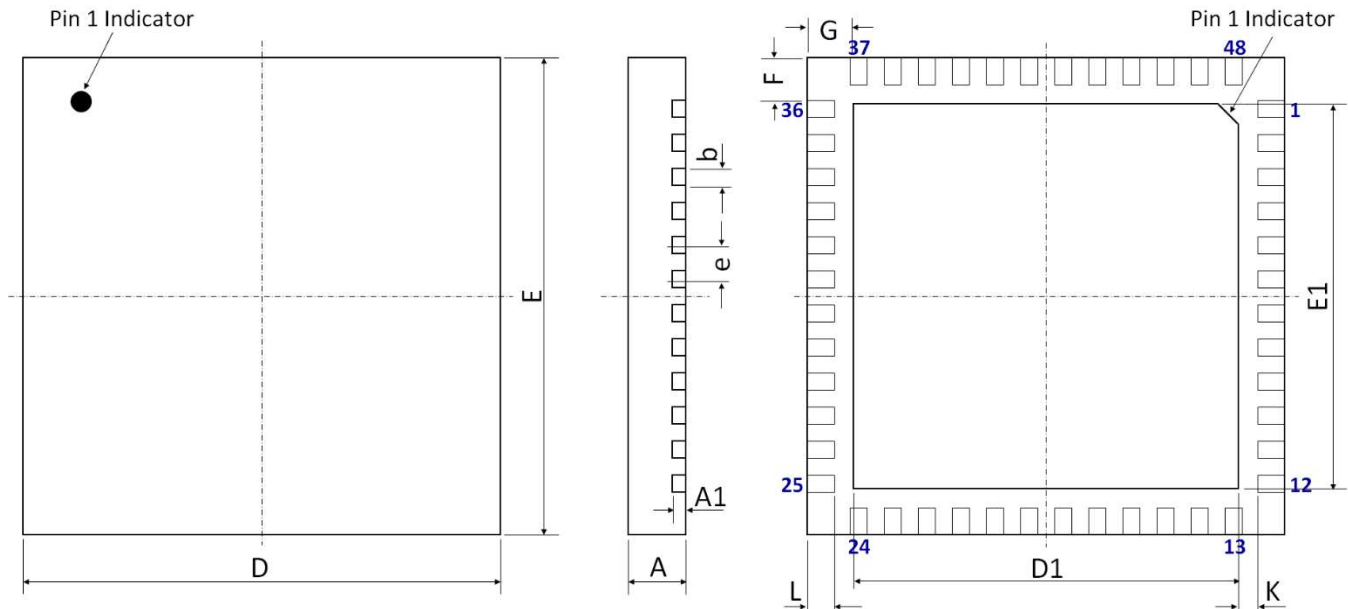

Figure 5 Device Package Drawing
 (All dimensions are in mm)

Table 7 Device Package Dimensions

Dimension	Value (mm)	Tolerance (mm)	Dimension	Value (mm)	Tolerance (mm)
A	0.85	±0.05	E	7.00 BSC	±0.05
A1	0.203	±0.02	E1	5.65	±0.06
b	0.25	+0.05/-0.07	F	0.625	±0.05
D	7.00 BSC	±0.05	G	0.625	±0.05
D1	5.65	±0.06	L	0.40	±0.05
e	0.50 BSC	±0.05	K	0.275	±0.05

Note: Lead finish: Pure Sn without underlayer; Thickness: 7.5µm ~ 20µm (Typical 10µm ~ 12µm)

Attention:

Please refer to application notes [TN-001](#) and [TN-002](#) at <http://www.tagoretech.com> for PCB and soldering related guidelines.

Top Marking Specifications:

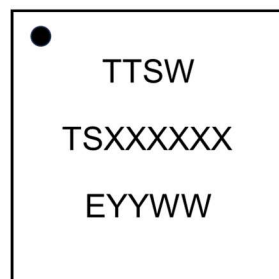

- = Pin 1 indicator
- TTSW = Tagore Technology SWitch
- TSXXXXXX = Part number (8 digits max)
- E = A fixed letter before the date code
- YY = Last two digits of assembly year
- WW = Assembly work week

12.0 PCB Land Design

Guidelines:

- [1] 4-layer PCB is recommended.
- [2] Via diameter is recommended to be 0.3mm to prevent solder wicking inside the vias.
- [3] Thermal vias shall only be placed on the center pad.
- [4] The maximum via number for the center pad is $11(X) \times 11(Y) = 121$.

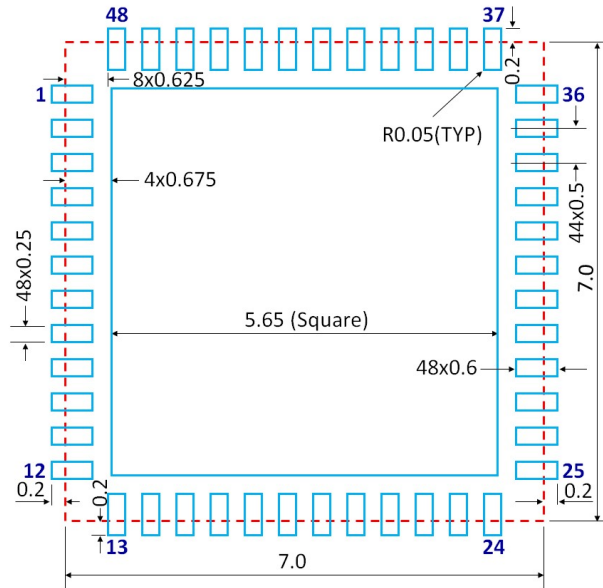

Figure 6 PCB Land Pattern
(Dimensions are in mm)

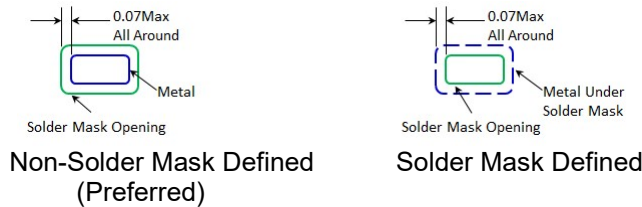

Figure 7 Solder Mask Pattern
(Dimensions are in mm)

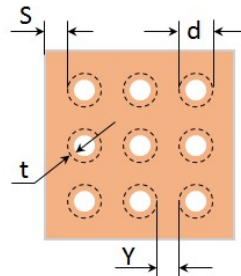

Figure 8 Thermal Via Pattern
(Recommended Values: $S \geq 0.15\text{mm}$; $Y \geq 0.20\text{mm}$; $d = 0.3\text{mm}$; Plating Thickness $t = 25\mu\text{m}$ or $50\mu\text{m}$)

13.0 PCB Stencil Design

Guidelines:

- [1] Laser-cut, stainless steel stencil is recommended with electro-polished trapezoidal walls to improve the paste release.
- [2] Stencil thickness is recommended to be 125µm.

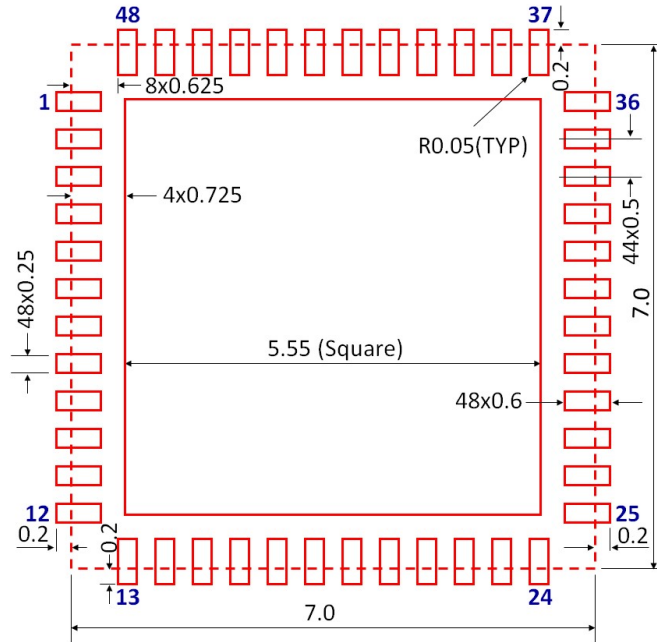

Figure 9 Stencil Openings
(Dimensions are in mm)

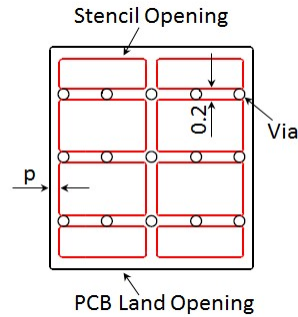

Figure 10 Stencil Openings Shall not Cover Via Areas If Possible
(Dimensions are in mm)

14.0 Tape and Reel Information

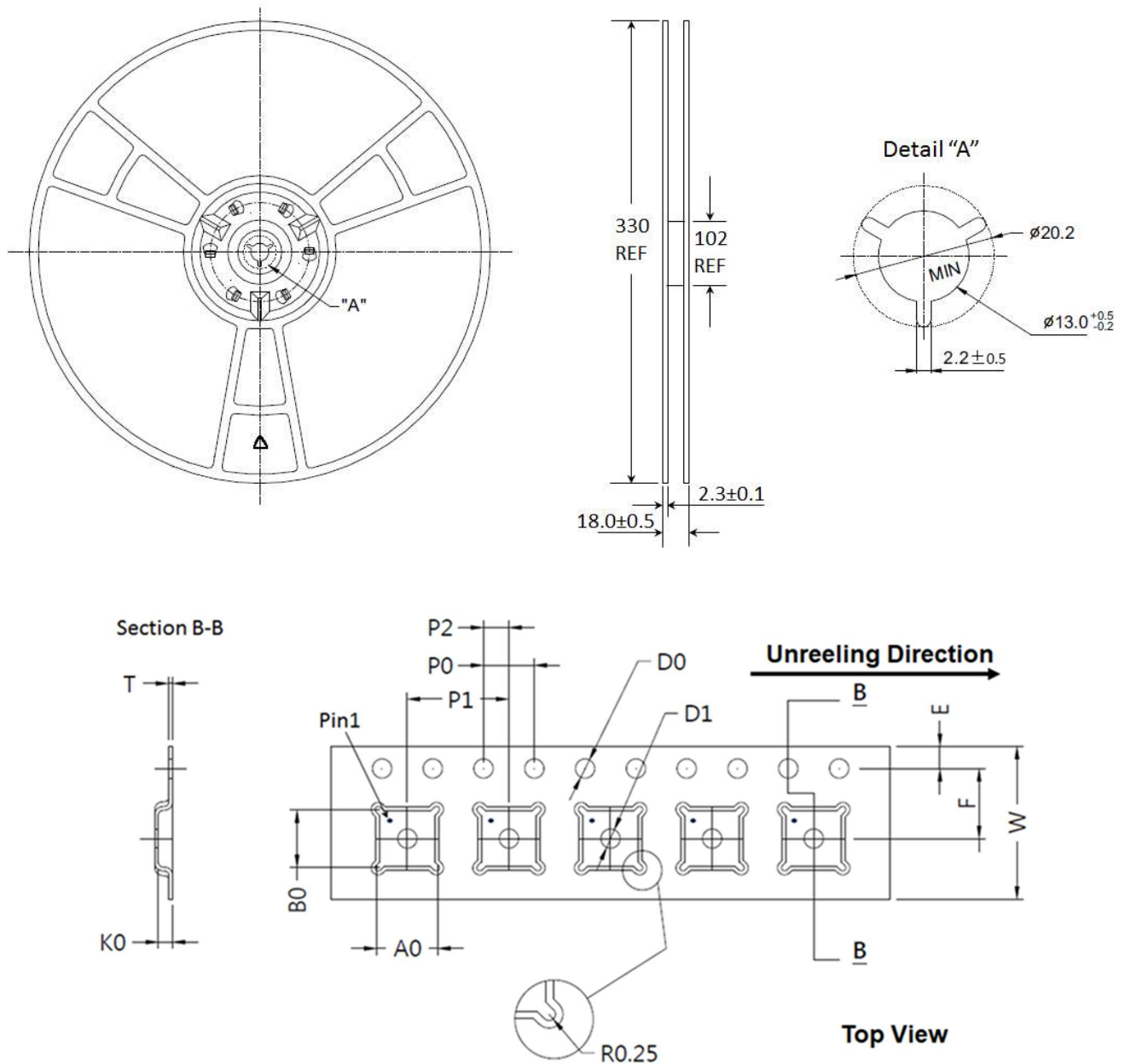

Figure 11 Tape and Reel Drawing

Table 8 Tape and Reel Dimensions

Dimension	Value (mm)	Tolerance (mm)	Dimension	Value (mm)	Tolerance (mm)
A0	7.35	±0.10	K0	1.10	±0.10
B0	7.35	±0.10	P0	4.00	±0.10
D0	1.50	+0.10/-0.00	P1	8.00	±0.10
D1	1.50	+0.10/-0.00	P2	2.00	±0.05
E	1.75	±0.10	T	0.30	±0.05
F	5.50	±0.05	W	12.00	±0.30

Edition Revision 2.0 - 2024-09-10**Published by**

TagoreTech Inc.
601 Campus Drive, Suite C1
Arlington Heights, IL 60004, USA

©2018 All Rights Reserved

Legal Disclaimer

The information provided in this document shall in no event be regarded as a guarantee of conditions or characteristics. TagoreTech assumes no responsibility for the consequences of the use of this information, nor for any infringement of patents or of other rights of third parties which may result from the use of this information. No license is granted by implication or otherwise under any patent or patent rights of TagoreTech. The specifications mentioned in this document are subject to change without notice.

Information

For further information on technology, delivery terms and conditions and prices, please contact TagoreTech: support@tagoretech.com.