

TSL8029N

Single Channel 2 – 5 GHz 100-Watt Receiver
Front End for MACRO base station

Application Note: TSL8029N EVB E

Application Note

2900 MHz~3300 MHz

5 V, 90 mA [RX-HG]

5 V, 50 mA [RX-LG]

Rev-2.0

List of Contents

- 1 General Description
- 2 TSL8029N-EVB-E Board Details
- 3 TSL8029N-EVB-E Bill of Material
- 4 TSL8029N-EVB-E Biasing sequence
- 5 TSL8029N-EVB-E Board Measurement Summary
- 6 TSL8029N-EVB-E Board Measurement Results

1. General Description

The TSL8029N is a single-channel, integrated RF, front-end, multichip module designed for different applications. The device operates from 2 GHz to 5 GHz. The TSL8029N is configured with a cascading, two-stage, GaAs LNA and a GaN based SPDT switch.

In high gain mode, the cascaded two-stage LNA and switch offer a low noise figure of 1.4 dB and a high gain of 33 dB at 3.6 GHz with an output third-order intercept point (OIP3) of 33 dBm (typical) at high gain mode. In low gain mode, one stage of the two-stage LNA is in bypass, providing 14.5 dB of gain at a lower current of 50 mA. In power-down mode, the LNAs are turned off and the device draws 4 mA.

In transmit operation, when RF inputs are connected to a termination pin (TX), the switch provides low insertion loss of 0.5 dB at 3.6 GHz and handles long-term evolution (LTE) average power (8 dB peak to average ratio (PAR)) of 50 dBm for full lifetime operation.

The device comes in an RoHS compliant, compact, 5 mm x 5 mm x 0.85 mm, 32-lead QFN. TSL8029N EVB-E is tuned for 2.9-3.3 GHz.

2. TSL8029N-EVB-E Board Details

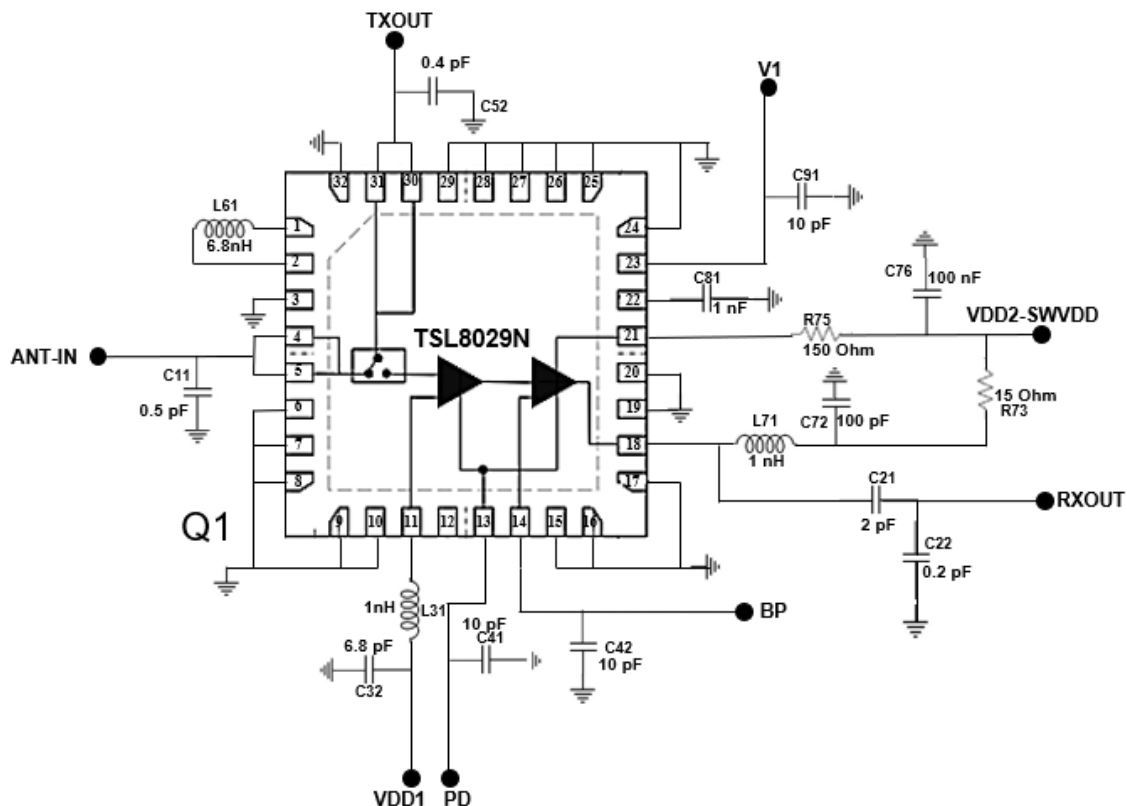

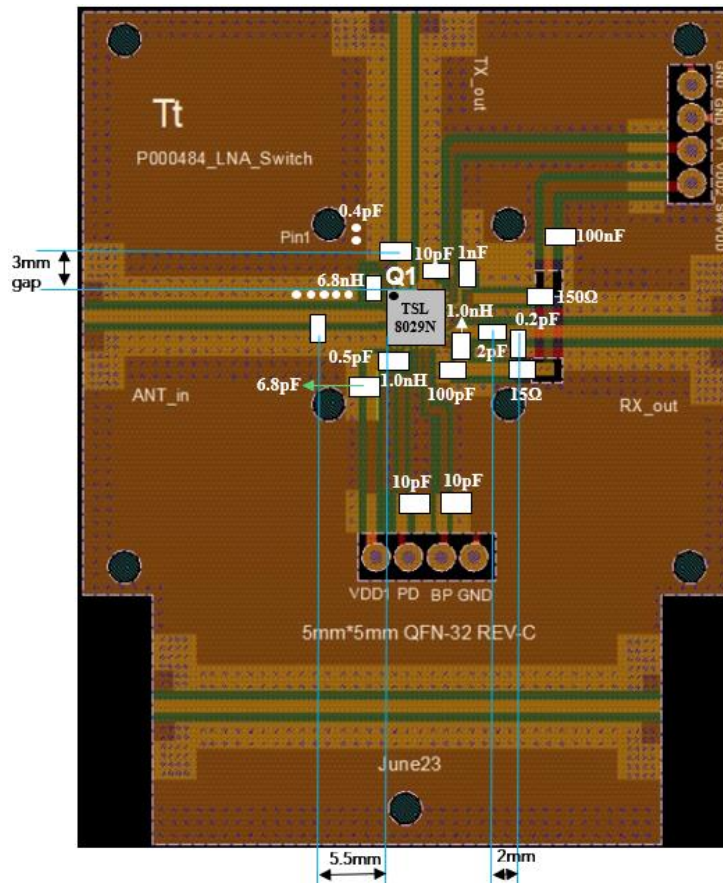

Note: Series cap on ANT and TX ports should have 250 V voltage ratings to handle 100 W power. The heatsink needs to be added at bottom of this board for proper power spreading.

Figure 2.1 TSL8029N-EVB-E 2900 MHz ~ 3300 MHz Schematic and EVB Layout

3. TSL8029N-EVB-E Bill of Material

Component ID	Value	Manufacturer	Recommended Part Number	Qty
C11	0.5 pF	Murata	600S0R5BT250XT	1
C21	2 pF	Murata	GJM1555C1H2R0BB01D	1
C22	0.2 pF	Murata	GJM1555C1HR20BB01J	1
L31, L71	1 nH	Coil craft	0402DC-1N0XJRW	2
C32	6.8 pF	Murata	GJM1555C1H6R8BB01D	1
C41, C42, C91	10 pF	Murata	GJM1555C1H100JB01D	3
C52	0.4 pF	Murata	600S0R4BT250XT	1
L61	3.9 nH	Coil craft	0402DC-3N9XGRW	1
C72	100 pF	AVX	04025A101JAT4A	1
R73	15 Ω	Panasonic	ERJ-H2RD15R0X	1
R75	150 Ω	Panasonic	ERJ-2RHD1500X	1
C76	100 nF	TDK	C1005X7R1H104K050BE	1
C81	1 nF	Murata	04025C102JAT2A	1
PCB	Rogers RO4350B, 20 mils, 1 oz copper			1

Table 3.1 TSL8029N-EVB-E BOM

4. TSL8029N-EVB-E Biasing Sequence

Turn ON Device	Turn OFF Device
<ol style="list-style-type: none"> 1. Apply bias to the VDD2_SWVDD and VDD1=5 V test points. 2. Apply bias to the V1 test point. 3. Apply bias to the BP test points. 4. Apply bias to the PD test point. 5. Apply an RF input signal. 	<ol style="list-style-type: none"> 1. Turn RF power off. 2. Turn off V1, BP and PD 3. Turn off VDD2_SWVDD and VDD1=5 V test points.

Table 4.1 TSL8029N-EVB-E Bias and Sequencing

5. TSL8029N-EVB-E Board Measurement Summary

Frequency (MHz)	Mode	S21 (dB)	S11 (dB)	S22 (dB)	Noise Figure(dB)	OP1dBm	OIP3dBm
2900	RX Low Gain	13.5	-11.2	-7.1	1.4	13.5	22
3000		13.7	-11.8	-6.3	1.4	13.5	30
3100		13.7	-12.5	-6.1	1.4	13.0	22
3200		13.7	-12.9	-5.9	1.4	12.5	22
3300		13.7	-13.5	-6.0	1.4	12.3	21
2900	RX High Gain	31.1	-10.5	-13.8	1.4	20.8	32.2
3000		32.8	-11.1	-10.2	1.3	20.7	32.0
3100		33.2	-10.9	-10.2	1.3	20.2	30.4
3200		33.1	-10.7	-10.8	1.4	20	31
3300		32.8	-11.0	-12.2	1.4	20	31
2900	TX	-0.7	-15.5	-14.2			
3000		-0.7	-15.9	-14.4			
3100		-0.8	-15.3	-14.3			
3200		-0.7	-15.7	-14.4			
3300		-0.8	-15.7	-14.4			

Table 5.1 TSL8029N-EVB-E Electrical Characteristics Summary

6. TSL8029N-EVB-E Test Results

All the tests are carried out at room temperature.

6.1. S parameters



Figure 6.1.1. S parameters of TSL8029N-EVB-E RX-LG 5 V, 50 mA



Figure 6.1.2. S parameters of TSL8029N-EVB-E RX-HG 5 V, 90 mA

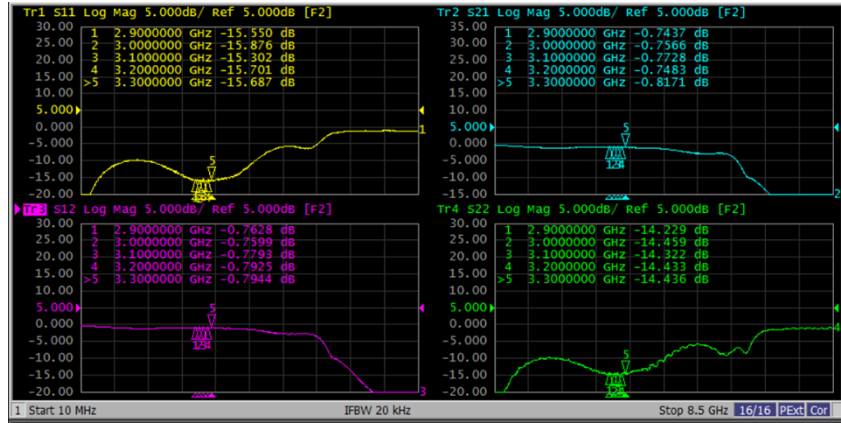

Figure 6.1.3. S parameters of TSL8029N-EVB-E TX

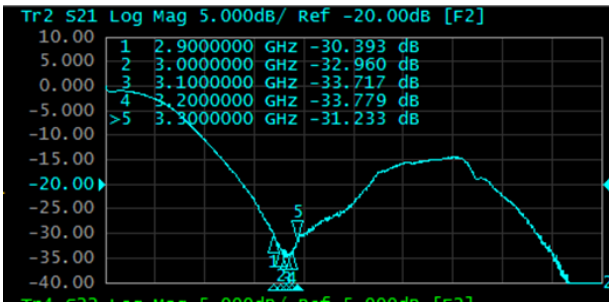

Figure 6.1.4. ANT to TX isolation of TSL8029N-EVB-E when RX-LG is on

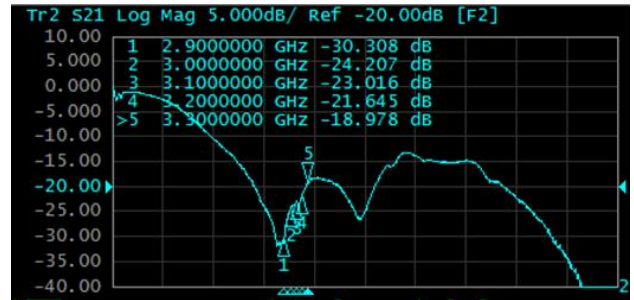

Figure 6.1.5. ANT to TX isolation of TSL8029N-EVB-E when RX-HG is on

6.2. SMA-SMA Noise Figure Test Results

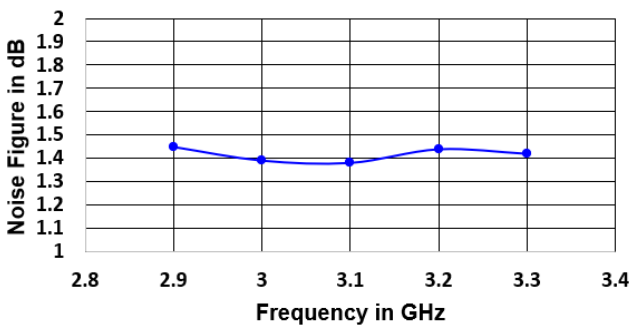

Figure 6.2.1. SMA-SMA Noise Figure of TSL8029N-EVB-D for 5 V, 50 mA for RX-LG mode

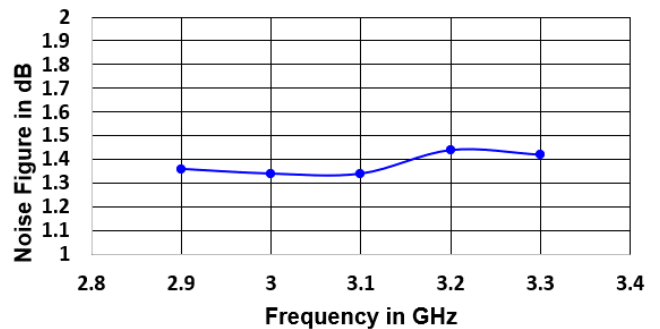

Figure 6.2.2. SMA-SMA Noise Figure of TSL8029N-EVB-D for 5 V, 90 mA for RX-HG mode

****Note:** The trace loss is within the range of 0.2 dB, resulting in a de-embedded NF of 1.2 to 1.25 dB

6.3. Large Signal Test Results

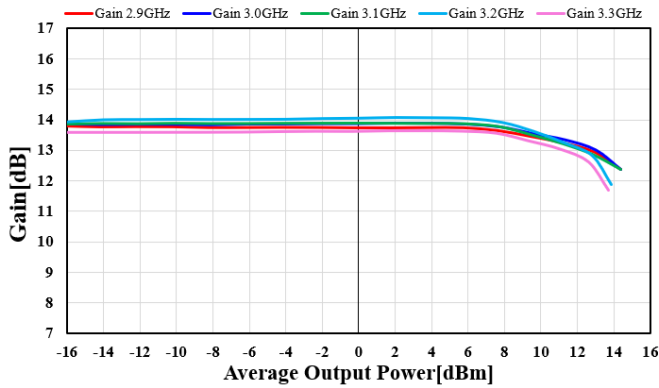

Figure 6.3.1. Gain vs P_{OUT} of TSL8029N-EVB-E for 5V 50mA for RX-LG mode

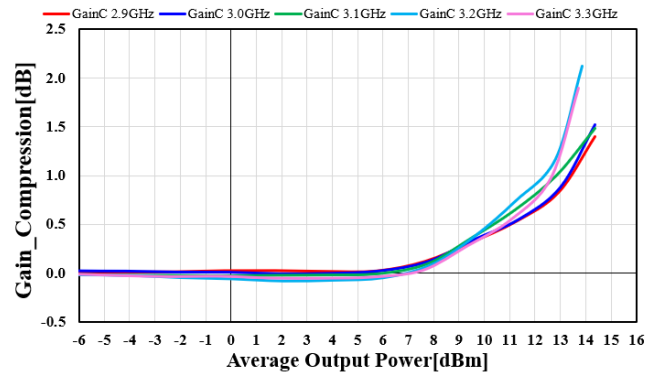

Figure 6.3.2 Gain compression vs P_{OUT} of TSL8029N-EVB-E for 5 V, 50 mA for RX-LG mode

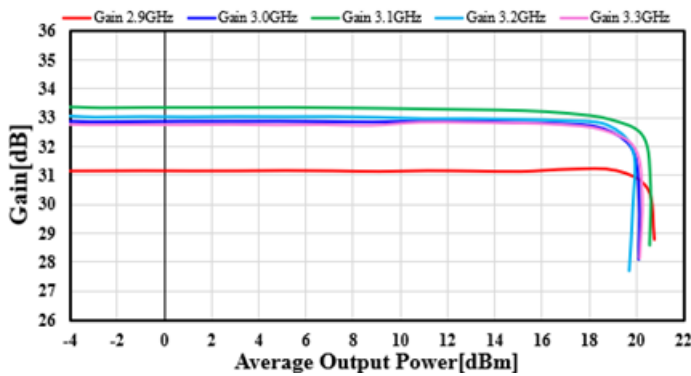

Figure 6.3.3. Gain vs P_{OUT} of TSL8029N-EVB-E for 5 V, 90 mA for RX-HG mode

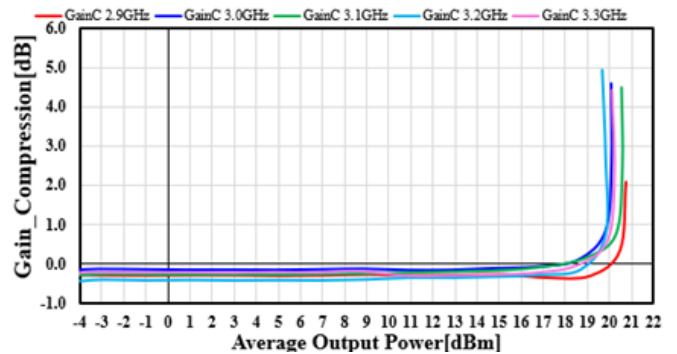

Figure 6.3.4 Gain compression vs P_{OUT} of TSL8029N-EVB-E for 5 V, 90 mA for RX-HG mode

6.4. OIP3 Test Results

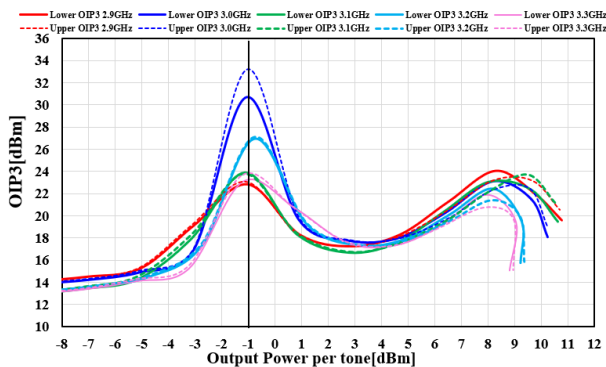

Figure 6.4.1 OIP3dBm vs P_{OUT} /tone of TSL8029N-EVB-E for 5 V, 50 mA for RX-LG mode

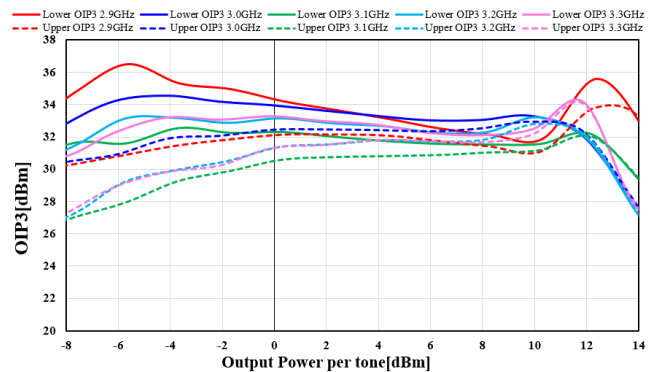

Figure 6.4.2 OIP3dBm vs P_{OUT} /tone of TSL8029N-EVB-E for 5 V, 90 mA for RX-HG mode

Edition Revision 2.0 - 2024-07-30

Published by

TagoreTech Inc.

601 W Campus Dr. Ste C1

Arlington Heights, IL 60004, USA

©2024 All Rights Reserved

Legal Disclaimer

The information provided in this document shall in no event be regarded as a guarantee of conditions or characteristics. TagoreTech assumes no responsibility for the consequences of the use of this information, nor for any infringement of patents or of other rights of third parties which may result from the use of this information. No license is granted by implication or otherwise under any patent or patent rights of TagoreTech. The specifications mentioned in this document are subject to change without notice.

Information

For further information on technology, delivery terms and conditions and prices, please contact TagoreTech: support@tagoretech.com.